

DELPHI SERIES ASYNCHRONOUS THREE-PHASE ELECTRIC MOTORS

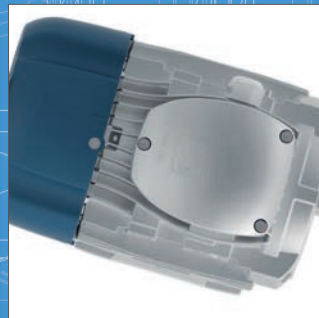
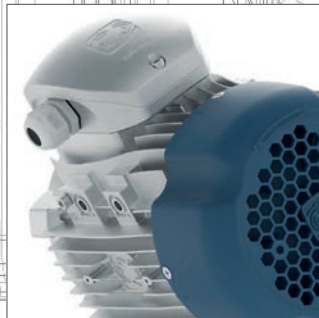
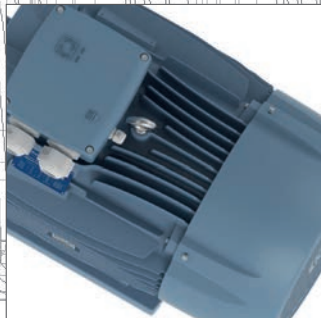
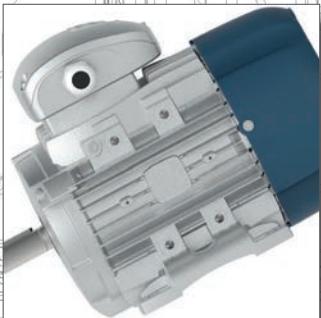

CERTIFICATE CERTIFICADO CERTIFICAT CERTIFICADO CERTIFICAT CERTIFICATE CERTIFICADO CERTIFICAT CERTIFICATE CERTIFICADO CERTIFICAT CERTIFICATE CERTIFICADO CERTIFICAT

CERTIFICATO

Nr. 50 100 1185 Rev.012

SI ATTESTA CHE / THIS IS TO CERTIFY THAT
IL SISTEMA DI GESTIONE PER LA QUALITÀ DI
THE QUALITY MANAGEMENT SYSTEM OF



SEDE LEGALE E OPERATIVA:
REGISTERED OFFICE AND OPERATIONAL SITE
VIA LE GHISSELLE 20
IT - 25014 CASTENEDOLO (BS)

E CONFORME AI REQUISITI DELLA NORMA
HAS BEEN FOUND TO COMPLY WITH THE REQUIREMENTS OF
UNI EN ISO 9001:2015

Progettazione e fabbricazione di motori elettrici, riduttori meccanici ed inverter (IAF 19, 18)

Design and manufacture of electrical motors, mechanical gearboxes and variable speed drives (IAF 19, 18)



Per l'Organismo di Certificazione
For the Certification Body
TUV Italia S.r.l.

Validità / Validity

Dal / From: 2025-03-03

Al / To: 2028-03-02

Data emissione /
Issuing Date

2025-02-03

PRIMA CERTIFICAZIONE / FIRST CERTIFICATION: 2001-07-20

"LA VALIDITÀ DEL PRESENTE CERTIFICATO È SOTTOPOSTA A SORVEGLIANZA PERIODICA 12 MESI E AL PRESARE COMPLETO DEL SISTEMA DI GESTIONE AZIENDALE CON FREQUENZA TRIENNALE"
"THE VALIDITY OF THE PRESENT CERTIFICATE DEPENDS ON THE ANNUAL SURVEILLANCE EVERY 12 MONTHS AND ON THE COMPLETE REVIEW OF COMPANY'S MANAGEMENT SYSTEM AFTER THREE-YEARS"

TUV Italia • Gruppo TÜV SÜD • Viale Feltrino, 280/6 • 20126 Milano • Italia • www.tuv.it

TUV®



Autorizzazione AEO

IT AEOF 21 1809

1. Titolare dell'Autorizzazione AEO

MOTIVE S.R.L.
Codice EORI IT03580280174

2. Autorità che rilascia l'Autorizzazione

Agenzia delle Dogane e dei Monopoli
Direzione Centrale Dogane
Ufficio AEO, compliance e grandi imprese

3. Stabile organizzazione

Il Titolare indicato nel riquadro 1 è un

Operatore economico autorizzato
Semplificazioni doganali / Sicurezza (AEOF)

3. Data di validità dell'Autorizzazione 15/05/2021

Il Direttore dell'Ufficio

CERTIFICATE

CERTIFICADO

CERTIFICAT

CERTIFICATE

CERTIFICADO

CERTIFICAT

CERTIFICATE

EU-TYPE EXAMINATION CERTIFICATE

Equipment or Protective System intended for use
in potentially explosive atmospheres
Directive 2014/34/EU

- (1)
- (2)
- (3) EU-Type Examination Certificate number:
TÜV IT 20 ATEX 048 X Rev 1
- (4) Equipment or Protective System: Three-phase asynchronous electric motors DELPHI series
- (5) Manufacturer: **MOTIVE S.r.l.**
- (6) Address: **Via Le Ghiselle 20
I-25014 CASTENEDOLO (BS) ITALY**

(7) This equipment or protective system and any acceptable variation thereto is specified in the schedule to this certificate and the documents therein referred to.

(8) TÜV Italia, notified body no. 0948 in accordance with Article 17 of Directive 2014/34/EU of the European Parliament and of the Council, dated 26 February 2014, certifies that this product has been found to comply with the Essential Health and Safety Requirements relating to the design and construction of products intended for use in potentially explosive atmospheres given in Annex II to the Directive.

The examination and test results are recorded in confidential report no. R 20 EX 046 Rev. 1.

(9) Compliance with the Essential Health and Safety Requirements has been assured by compliance with:
EN IEC 60079-0:2018 EN IEC 60079-7:2015/A1:2018 EN 60079-31:2014

(10) If the sign "X" is placed after the certificate number, it indicates that the equipment or protective system is subject to special conditions for safe use specified in the schedule to this certificate.

(11) This EU - TYPE EXAMINATION CERTIFICATE relates only to the design and construction of the specified product. Further requirements of the Directive apply to the manufacturing process and supply of this product. These are not covered by this certificate.

(12) The marking of the product shall include the following:
**II 2G Ex eb IIC T6, T3 Gb
II 2D Ex tb IIC T85°C, T120°C Db**

This certificate may only be reproduced in its entirety and without any change, schedule included.

Issue date: 12th March 2025
1st Issue date: 17th February 2021

ACCREDIA
PRD N° 081B

Membro degli Accordi di Mutual Recognition
EA, IAF & IAC
Signatory of EA, IAF and IAC Mutual Recognition Agreements



TUV Italia S.r.l.
Notified body N° 0948

Industry Service - Real Estate & Infrastructure
Managing Director

TUV Italia has been authorized by Italian government to operate as notified body for the certification of equipment or protective systems intended for use in potentially explosive atmospheres. This document is not valid without official signature and logo. The official reference code is 20237347.

page 1 di 14

TUV®



VISIT AND KNOW MOTIVE THANKS TO THE
MOVIE ON WWW.MOTIVE.IT



Technical characteristics
sizes 56 -132 pag. 4-5



Technical characteristics
sizes 160-355 pag. 6

DELFIRE series pag. 7



Efficiency pag. 8-9



CE Marking
Delphi EX pag. 10

CCC Marking pag. 11

EAC Marking

Marine Motors certified by RINA



Motive motors protection
Duty Service pag. 12

IP Protection Index pag. 13



Working conditions
Assisted power cooling

Encoder pag. 14

Wiring diagrams pag. 15



Three-phase self-braking
motors series Delphi AT pag. 16

Brake description pag. 17

Brake operation

Adjustment



Manual release/IP/braking surface
micro-switches to detect brake
position / Power supply pag. 18

Power supply pag. 19



Configurator pag. 20

Motor configurations
and installation positions pag. 21



Table of dimensions pag. 22-23

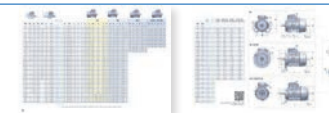

Technical data pag. 24-25



Technical data pag. 26-27

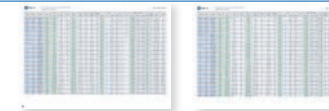

Technical data pag. 28-29

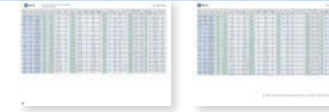

Technical data pag. 30-31



Technical data pag. 32

Components list pag. 33

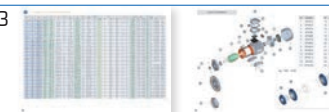

Rubber seal rings
and bearings pag. 34

Terms of sale
and guarantee pag. 35



TECHNICAL CHARACTERISTICS SIZES 56 -132

Motive motors are built according to international standard regulations; each size throughout the construction forms is calculated with reference to the tables of standard IEC 72-1.

Motive asynchronous three-phase delphi series motors are closed, and externally ventilated.

The frame, up to 132 included, is made in die casting aluminium alloy, from size 160 up to 355 the frame is made in cast iron.

All DELPHI motors are three-phase, multiple voltage multi-frequency 50/60Hz, F class insulation, (H+ on request) S1 continuous duty service, IP55 protection (IP56, 66 and 67 on request) IE2, IE3 or IE4 efficiency class tropicalized winding suitable for inverter power supply

IE2, high efficiency class IEC 60034-30-1

IE3, premium efficiency class IEC 60034-30-1

IE4, super premium efficiency class IEC 60034-30-1

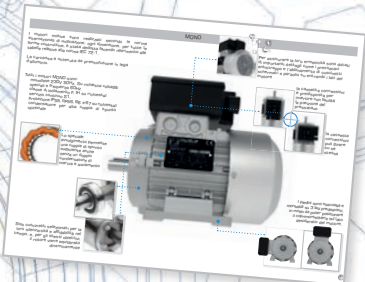

Download from www.motive.it the catalogue of 1PH motors "MONO" series

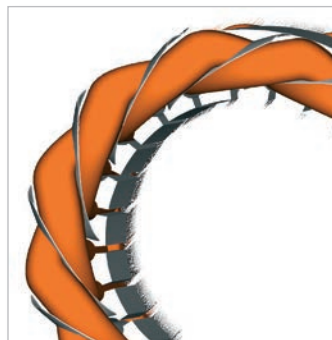

The copper is impregnated with a double layer of H class insulating enamel to ensure high resistance to electrical, thermal and mechanical stress. The phases are further isolated by another layer of Nomex film to protect the motors from the voltage peaks that usually occur when the motor is controlled by an inverter.

Bearings selected for their silence and reliability and, for the same objectives, the cage rotor is dynamically balanced.

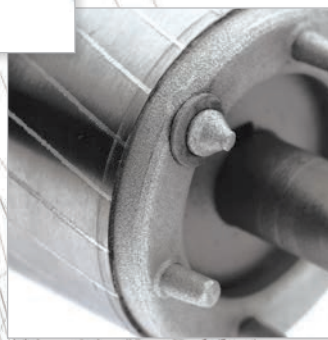

All three-phase Delphi motors, from size 56 to size 355, standard, ATEX, or brake motors, are covered by the international type approval certification for marine use issued by RINA.

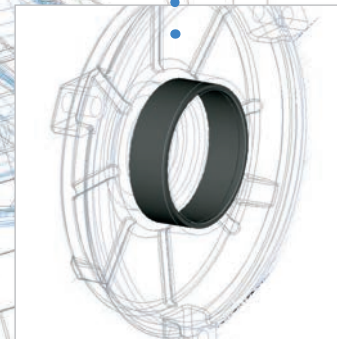

From type 90, a steel insert is provided in the bearing slot of the aluminum flanges, to resist to radial mechanical forces with a fair degree of security

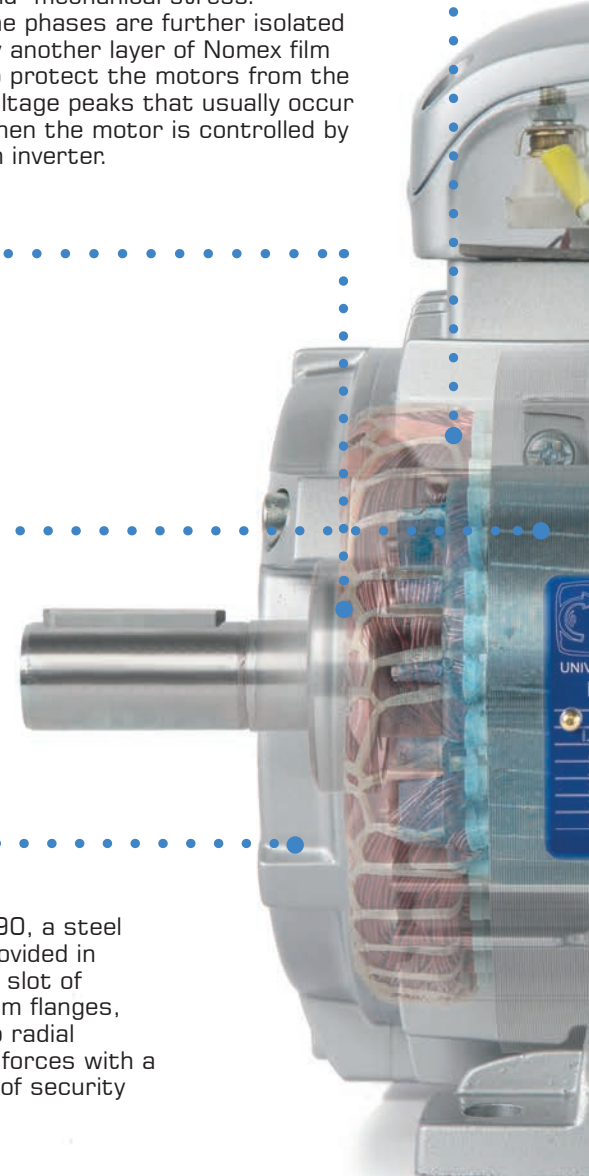

REGISTERED DESIGN

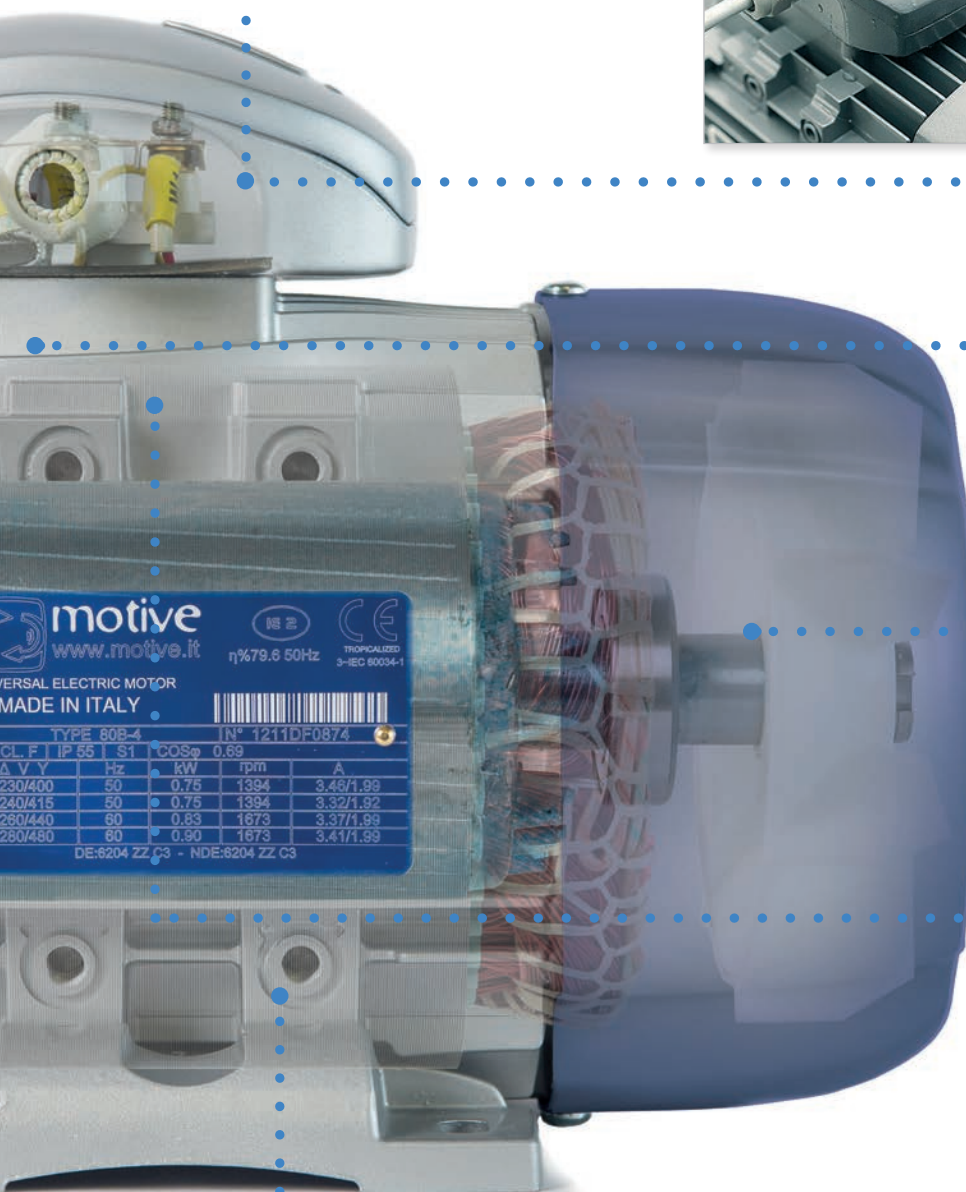

motive
www.motive.it

UNIVERSAL ELECTRIC MOTOR
MADE IN ITALY

TYPE 60B-4 IN° 1211DF0874

CL. F	IP 55	S1	COSφ	0.89
Δ V Y	Hz	kW	rpm	A
230/400	50	0.75	1394	3.48/1.99
240/415	50	0.75	1394	3.32/1.92
260/440	60	0.83	1673	3.37/1.99
280/480	60	0.90	1673	3.41/1.99

DE:8204 ZZ C3 - NDE:8204 ZZ C3



Aiming the maximum protection, the motors are equipped with important details like the pull-resistant cable gland and the combination of bearings with two shields each with rubber seal rings

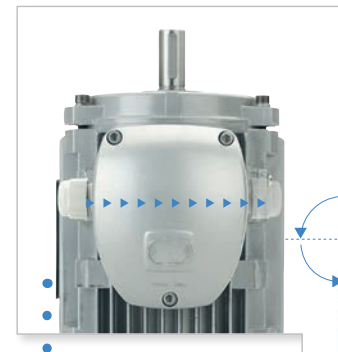

Cable gland can be easily moved on both the sides of the connection box, thanks to the screw cap

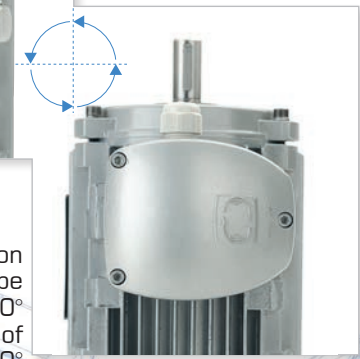

The connection box can be rotated of 360° with steps of 90°

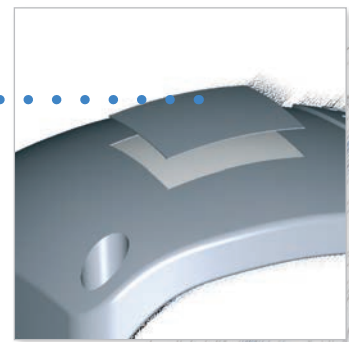

To protect them by the rust, motive motors are painted in silver RAL9006 colour

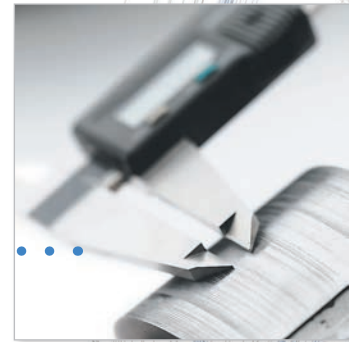

Performance excellence is granted by the low loss CRNO "FeV" magnetic laminations adoption, instead then the usual Semi Processed/Decarb "FeP01". FeV laminations provide higher efficiency, lower heating, energy saving and longer life to insulation materials

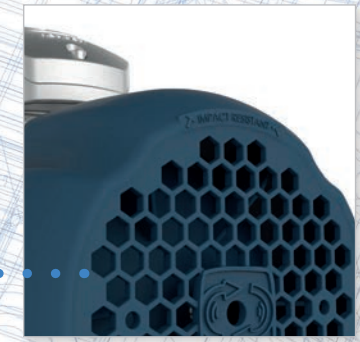

Very thick and made of a special plastic material, the fan cover is:

- impact resistant
- soundproofing
- scratchproof
- rustproof

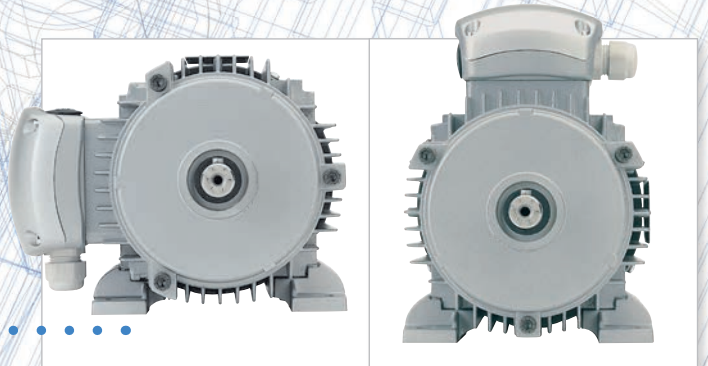

From size 56 to size 132, feet are detachable, and can be fixed on 3 sides of the housing, thus permitting the terminal box to be positioned up, right or left.

TECHNICAL CHARACTERISTICS **SIZES 160-355**

Motive three phase motors from size 160 up to size 355 are made in cast-iron and have all those main features of the Delphi series, among which:

- standardized dimensions according to International standards (IEC 72-1)
- multiple voltage and multi-frequency 50/60Hz,
- F class insulation, [oupon request H or H+ (delfire)]
- S1 continuous duty service,
- IP55 protection (IP56, 66 and 67 on request)
- tropicalized winding and reinforced insulation
- suitable for inverter power supply* [from 110kW and up we recommend to order the motor with insulated barings (option)]

IE2, high efficiency class IEC 60034-30-1

IE3, premium efficiency class IEC 60034-30-1

IE4, super premium efficiency class IEC 60034-30-1

Keeping the same sealing system of the whole delphi series, the terminal box up to size 280 is made in aluminum, thus guaranteeing its IP65 protection index without being affected by the usual finishing imperfections of the cast iron

From size 160 up to 280, we mount ZZ auto-lubricated bearings, thus avoiding the need of a periodical re-greasing maintenance

Instead, from size 315 and up, they are provided with lubricators. 4, 6 and 8 poles motors drive end bearings are in fact of open roller type, in order to withstand eventual extraordinary radial loads (see paragraph "components list")

provided with 3 PTC thermistors that protect the motor and the system by operation anomalies

equipped by lifting eyebolts [one for B3 version (feet fixing), two for B5 version (flange fixing)]

The terminal box can be rotated of 360° with steps of 90°

Given the high torque, the fixing is ensured by feet integrally casted with the housing

Upon request, motive can anyway mount the terminal box laterally, on the right or the left

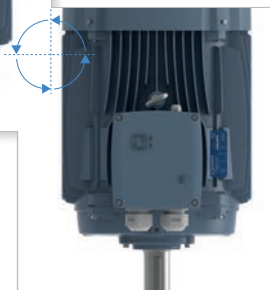
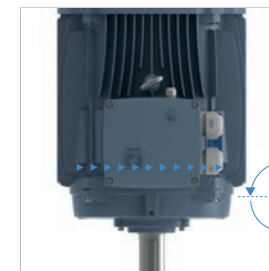

DELFIRESERIES, 100°C RESISTANT MOTORS

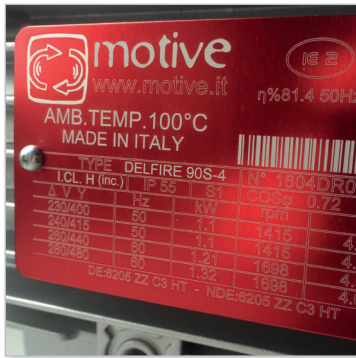

“DELFIRESERIES” is an innovative range of three phase motors specifically designed to work in an ambient temperature of 100°C, like for instance the one of the ventilation of furnaces and dryers, in S1 continuous duty

The used technology finds its origin in EN 12101-3 fire emergency motors for smoke evacuation, but instead of being intended for working for few hours only, it is designed to offer an S1 continuous duty service and the same lifespan of a normal motor in a normal ambient. The main features are:

- metal cable glands and ventilation, viton gaskets and seals, high temp bearings, steel bearing seats

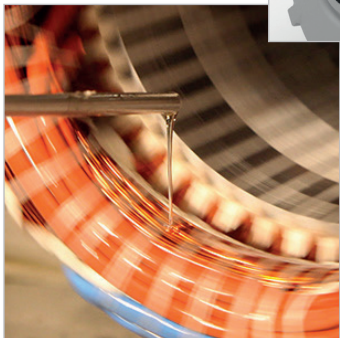
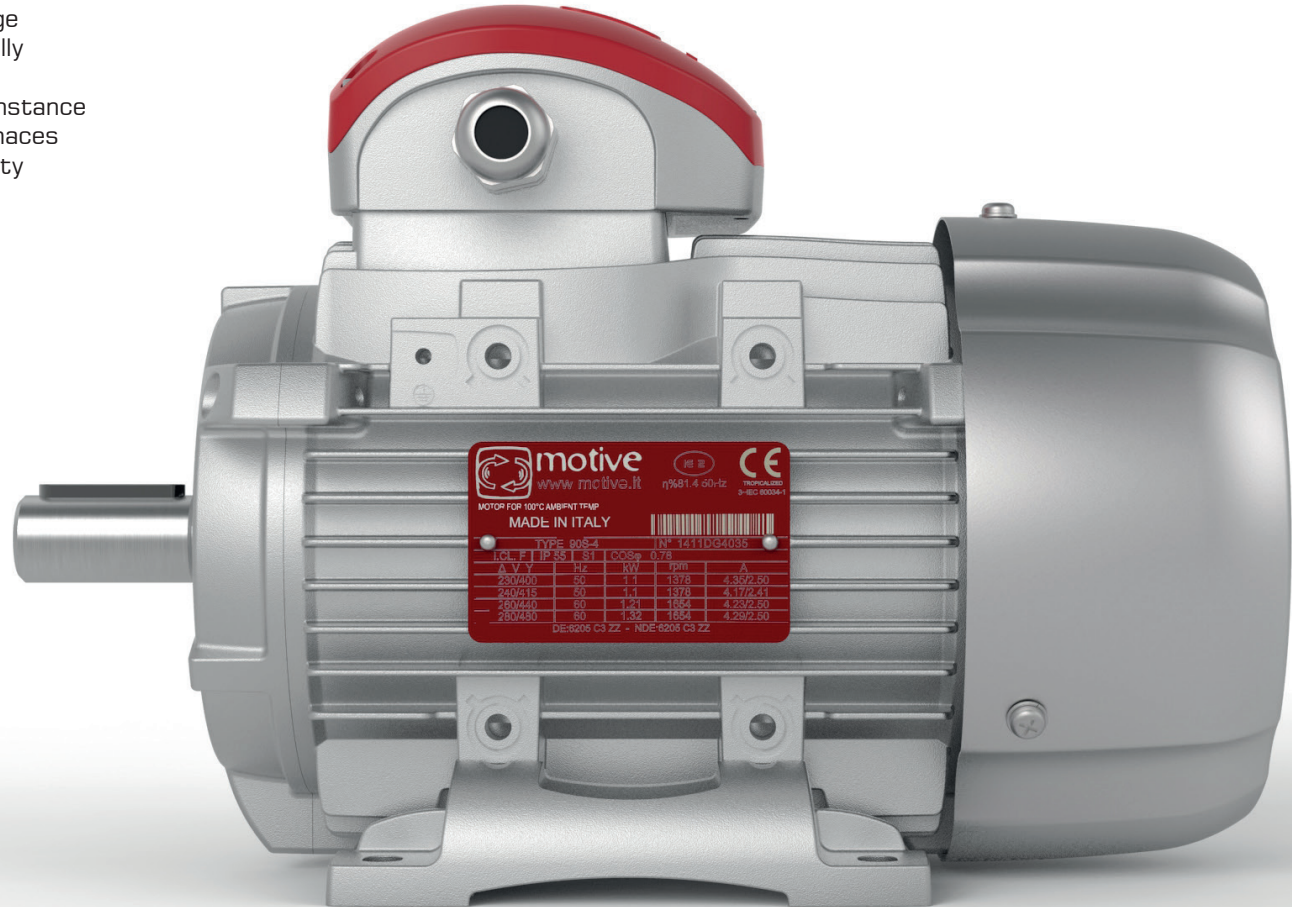

- defluxed winding for a low temp rise, dual coated magnet wires, increased H class:
 - Double impregnation: varnished twice and re-baked. The process assures the coverage of pin holes. The increased solid content layer increases the high voltage capacity of the motor and better protects it against surge voltages. The increased parasitic capacitance gives a higher impulse withstand capacity;
 - Gel Coat: the stator is then further protected by an epoxy compound which cures fast under hot conditions. Epoxy has very good fungus resistance properties, thus avoiding tracking failure, drastically reducing the service life of the motor. Epoxy also exhibits very good resistance to alkali as well as acids. Epoxy coating also allows for condensing humidity. The smoothly finished surface does not allow liquid water to stay on the windings

Available from size IEC 71 (0,25kW) up to size 250 (55kW), in 2-4-6 poles.

For the performance and dimensional data of delfire series, do not refer to the standard motors data contained in this catalogue. If needed, ask it to our commercial office.

EFFICIENCY

efficiency classes at 50Hz

(kW)	IE-1				IE-2				IE-3				IE-4			
	nr of poles				nr of poles				nr of poles				nr of poles			
	2	4	6	8	2	4	6	8	2	4	6	8	2	4	6	8
0.12	45.0	50.0	38.3	31.0	53.6	59.1	50.6	39.8	60.8	64.8	57.7	50.7	66.5	69.8	64.9	62.3
0.18	52.8	57.0	45.5	38.0	60.4	64.7	56.6	45.9	65.9	69.9	63.9	58.7	70.8	74.7	70.1	67.2
0.2	54.6	58.5	47.6	39.7	61.9	65.9	58.2	47.4	67.2	71.1	65.4	60.6	71.9	75.8	71.4	68.4
0.25	58.2	61.5	52.1	43.4	64.8	68.5	61.6	50.6	69.7	73.5	68.6	64.1	74.3	77.9	74.1	70.8
0.37	63.9	66.0	59.7	49.7	69.5	72.7	67.6	56.1	73.8	77.3	73.5	69.3	78.1	81.1	78	74.3
0.4	64.9	66.8	61.1	50.9	70.4	73.5	68.8	57.2	74.6	78	74.4	70.1	78.9	81.7	78.7	74.9
0.55	69.0	70.0	65.8	56.1	74.1	77.1	73.1	61.7	77.8	80.8	77.2	73	81.5	83.9	80.9	77
0.75	72.1	72.1	70	61.2	77.4	79.6	75.9	66.2	80.7	82.5	78.9	75	83.5	85.7	82.7	78.4
1.1	75	75	72.9	66.5	79.6	81.4	78.1	70.8	82.7	84.1	81	77.7	85.2	87.2	84.5	80.8
1.5	77.2	77.2	75.2	70.2	81.3	82.8	79.8	74.1	84.2	85.3	82.5	79.7	86.5	88.2	85.9	82.6
2.2	79.7	79.7	77.7	74.2	83.2	84.3	81.8	77.6	85.9	86.7	84.3	81.9	88	89.5	87.4	84.5
3	81.5	81.5	79.7	77.0	84.6	85.5	83.3	80.0	87.1	87.7	85.6	83.5	89.1	90.4	88.6	85.9
4	83.1	83.1	81.4	78.2	85.8	86.6	84.6	81.9	88.1	88.6	86.8	84.8	90	91.1	89.5	87.1
5.5	84.7	84.7	83.1	81.4	87	87.7	86	83.8	89.2	89.6	88	86.2	90.9	91.9	90.5	88.3
7.5	86	86	84.7	83.1	88.1	88.7	87.2	85.3	90.1	90.4	89.1	87.3	91.7	92.6	91.3	89.3
11	87.6	87.6	86.4	85.0	89.4	89.8	88.7	86.9	91.2	91.4	90.3	88.6	92.6	93.3	92.3	90.4
15	88.7	88.7	87.7	86.2	90.3	90.6	89.7	88.0	91.9	92.1	91.2	89.6	93.3	93.9	92.9	91.2
18.5	89.3	89.3	88.6	86.9	90.9	91.2	90.4	88.6	92.4	92.6	91.7	90.1	93.7	94.2	93.4	91.7
22	89.9	89.9	89.2	87.4	91.3	91.6	90.9	89.1	92.7	93	92.2	90.6	94	94.5	93.7	92.1
30	90.7	90.7	90.2	88.3	92	92.3	91.7	89.8	93.3	93.6	92.9	91.3	94.5	94.9	94.2	92.7
37	91.2	91.2	90.8	88.8	92.5	92.7	92.2	90.3	93.7	93.9	93.3	91.8	94.8	95.2	94.5	93.1
45	91.7	91.7	91.4	89.2	92.9	93.1	92.7	90.7	94	94.2	93.7	92.2	95	95.4	94.8	93.4
55	92.1	92.1	91.9	89.7	93.2	93.5	93.1	91.0	94.3	94.6	94.1	92.5	95.3	95.7	95.1	93.7
75	92.7	92.7	92.6	90.3	93.8	94	93.7	91.6	94.7	95	94.6	93.1	95.6	96	95.4	94.2
90	93	93	92.9	90.7	94.1	94.2	94	91.9	95	95.2	94.9	93.4	95.8	96.1	95.6	94.4
110	93.3	93.3	93.3	91.1	94.3	94.5	94.3	92.3	95.2	95.4	95.1	93.7	96	96.3	95.8	94.7
132	93.5	93.5	93.5	91.5	94.6	94.7	94.6	92.6	95.4	95.6	95.4	94	96.2	96.4	96	94.9
160	93.8	93.8	93.8	91.9	94.8	94.9	94.8	93.0	95.6	95.8	95.6	94.3	96.3	96.6	96.2	95.1
200-1000	94	94	94	92.5	95	95.1	95	93.5	95.8	96	95.8	94.6	96.5	96.7	96.3	95.4

In order to create a common system for the classification of induction motor efficiencies, IEC (International Electrotechnical Commission) issued the norm IEC 60034 "Rotating electrical machines"

- Part 30-1: Efficiency classes of single-speed, three-phase, cage-induction motors (IE-code)"-

- Part 2-1: Standard methods for determining losses and efficiency from tests-

In Europe it was a step ahead in the application of the Eco-design Directive for Energy-related Products (ErP) 2009/125/EC. It's based on such a normative picture and on the Ecodesign Regulation (EU) nr 640/2009, replaced in Oct 2019 by the Regulation (EU) 2019/1781, that:

- From June 2011, the efficiency of 2, 4, and 6 poles motors from 0.75kW up to 375kW lower than IE2 has been forbidden

- From 2015, the minimum efficiency for motors not equipped with an electronic variable speed drive from 7,5 to 375kW became IE3

- From 2017, the obligation of IE3 was extended to the motors not equipped with an electronic variable speed drive from 0,75kW to 5,5kW

We recommend to choose Motive VFD NEO or NANO

-From 1 July 2021: the energy efficiency of three-phase motors $\geq 0,75$ kW and ≤ 1.000 kW, with 2, 4, 6 or 8 poles, rated for direct

on-line operation (DOL), including ATEX (only exception Ex e) and brake motors, shall correspond to at least the IE3 efficiency level; the energy efficiency of three-phase motors with a rated output $\geq 0,12$ kW and $< 0,75$ kW, with 2, 4, 6 or 8 poles, including ATEX and brake motors, shall correspond to at least the IE2 efficiency level;

-From 1 July 2023: the energy efficiency of ATEX Ex eb with power $\geq 0,12$ kW and $\leq 1 000$ kW, with 2, 4, 6 or 8 poles, and single-phase motors with power $\geq 0,12$ kW shall correspond to at least the IE2 efficiency; the energy efficiency of three-phase motors which are not brake motors or ATEX motors, with power ≥ 75 kW and ≤ 200 kW, with 2, 4, or 6 poles, shall correspond to at least the IE4 efficiency



What did Motive do in this scenario?

- The measuring and calculation system of Motive motors efficiency is conform to the norm 60034-2-1. That's the one behind the data declared in the probative test-reports uploaded in motive web-site (each declared data, we remind it, is in fact supported, detailed and proven by such test reports that anyone can download from:



<https://www.motive.it/en/rapporti.php>

- From June 2011, IE1 motors are not produced anymore.

- IE3 "premium efficiency" electric motors are also available, and since 2023, IE4 "Super Premium Efficiency" motors as well.

- all 3PH motors below 0.75kW are min IE2 "high efficiency"

- IE2 motors with power higher than 0.75kW are still available, but their use in Europe is forbidden in case of direct on line operation

- The testing system, test reports, and data truth of Motive motors has been certified by IMQ, the main Italian certification body for electrical appliances. The same, in fact, has firstly inspected and qualified our internal testing laboratory according to the norm IEC/ISO 17025, and then supervised the internal efficiency tests on a sampling list of motors. Motive testing laboratory and procedures has also been certified by RINA (Certificate No. 2015/MI/01/53), and it is submitted to ISO:9001 TUV certification controls.

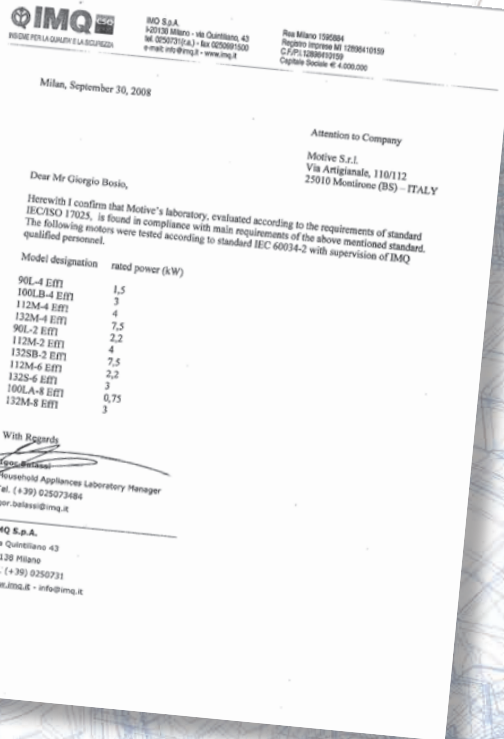

In 2020, the efficiency of Motive 3PH motors was also certified by CQC for the Chinese market.



Clients benefits are of many kinds:

BILL EFFECTS

The purchase cost of a motor is about 2-3% of the total costs of its life. The balance is energy consumption costs. Comparing IE3 motors to IE2, the purchase price difference is recovered in about one year of energy saving. Of course, such period length depends by the specific motor, the use of it and the local energy costs of each Country.

DURABILITY EFFECTS

Higher efficiency motors heat less, slowing down the aging cycle of the insulating materials and living longer. The average life is approximately from 35 to 40,000 hours for IE2 motors up to 15kW and 60,000 for IE2 bigger motors. IE3 motors can live approx 40% longer than IE2 motors.

AMBIENT EFFECTS

Electric motors use 85% of all electricity in industry. Higher efficiency motors have the further objective of sustainable development, reduction of CO₂ emissions and consequent improvement of the quality of the atmosphere with an objective of sustainable development, Reduction of CO₂ emissions and consequent improvement of the quality of the atmosphere.

Use Motive Energy web App to:

Calculate the energy bill savings the CO₂ reduction achieved by using our motors instead of lower-quality ones. Calculate the payback time if you invest in a higher-efficiency motor. Download an official certificate with all the results.

How to make a more efficient motor?

High efficiency can be seen in many ways: like the relation between output power and input absorbed power, or like a measure of the losses that born when converting the electric power in mechanical energy. From another perspective, high efficiency motors consume less energy to produce the same torque on the shaft. Basically, an high efficiency motor is the result of precise machining, lower frictions, a dynamically balanced rotor, smaller space between rotor and stator and of the use of better materials. The main factors for the design are based on the choice of the type of lamination sheets and windings. Motive motors are made with "FeV" magnetic lamination sheets, rather than the customary iron lamination sheets. Composition and thickness give to magnetic lamination sheets a very low W/Kg loosing factor. Lower specific losses mean less magnetising current for the same Power and torque (thus less heating).

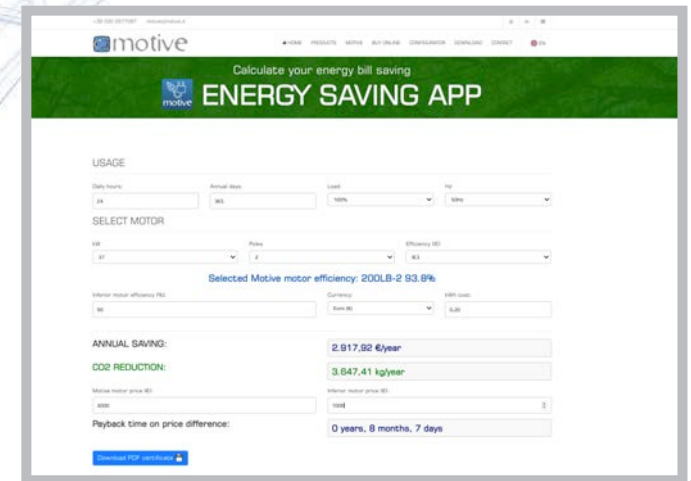

CE MARKING

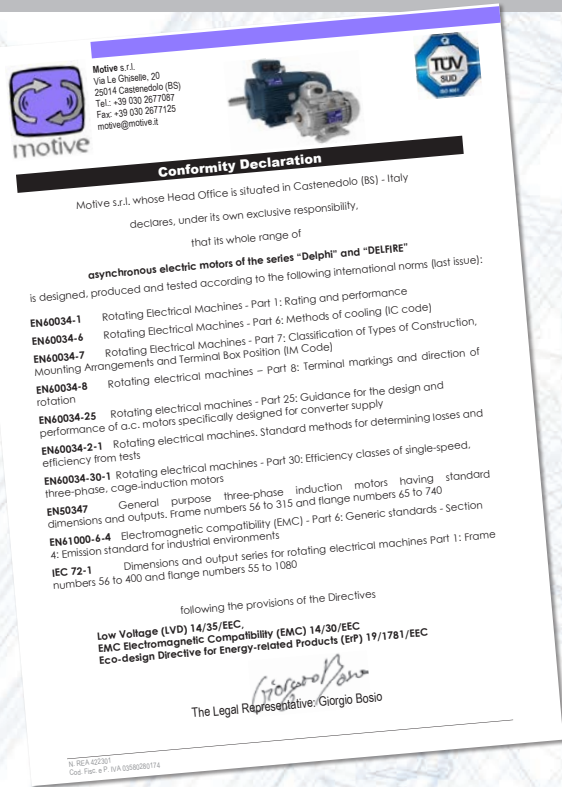

CE marking is referred to:

Low Voltage 14/35/EC

EMC Electromagnetic Compatibility 14/34/EC

Eco-design Directive for Energy-related Products (ErP) 09/125/EC

Note: The Machinery Directive (MD) 2006/42/EC excludes from its scope the electric motors (Art. 1, comma 2)

CE marking is put by Motive as a visible sign of the product compliance with the requirements of above mentioned directives. In order to reach this conformity, Motive motors respect the following standards:

EN 60034-1 - EN 60034-5 - EN 60034-6 - EN60034-7 - EN60034-8 - EN60034-2-1 - EN60034-30-1 - EN50347 - EN61000-6-4 - EN 60034-9 - EN 60034-25

DELPHI EX SERIES



II 2G Ex eb IIC T3, T4, T5, T6 Gb
II 2D Ex tb IIC T85°C...T120°C Db

ATEX is the conventional name of the Directive 14/34/EC for the equipment intended for use in potentially explosive atmospheres.



Motive delphi Ex motors differ from standard delphi motors because they are designed to be used, like motive "Ex" gearboxes, in the ATEX zones 1, 2, 21 and 22

Motive delphi Ex motors are in fact certified for such zones according to the norms EN 60079-0 - EN 60079-7 - EN 60079-31 by a notified body.

Their certification covers all duty types, from S1 to S9, and also operation with inverters of any brand. In the latter case, Motive also provides its Ex forced ventilation system, which is likewise suitable for all types of dust and gas, in category 2.

The Delphi Ex series is also available in a version for environments with temperatures up to 60°C, while still maintaining continuous duty S1 and an internal temperature of max 135°C (T4).

The very high efficiency and low losses also help limit the surface temperature, still under S1 duty, to just 120°C. Nevertheless, it can be further reduced to 100°C and 85°C with intermittent duty.

Similarly, the internal temperature for gas can drop from T4 (135°C) to T5 (100°C) and T6 (85°C).

On our website, you will also find the EAC Ex certification for Eurasian countries, NEPSI Ex certification for China, and Ex certification for Ukraine.

Note: as stated by TÜV in the certificate, for each motor, configuration, and temperature class, the Motive website configurator shows:

- the minimum and maximum ambient temperatures
- the admissible gas temperature classes



CCC MARKING

The electrical safety and the efficiency of Motive motors, with and without brakes, have been  certified by the CQC certification body, as required by Chinese laws, thus allowing them to be exported to China.



2024000401000706



2024000401000707

ЕВРАЗИЙСКИЙ ЭКОНОМИЧЕСКИЙ СОЮЗ
ДЕКЛАРАЦИЯ О СООТВЕТСТВИИ

ЕАЭС

Заявитель: Общество с ограниченной ответственностью «ПРИВОД ГРАНД РЕДУКТОР»
Место нахождения и адрес места осуществления деятельности: Российская Федерация, Смоленская область, 214004, город Смоленск, улица Багратиона, дом 4, офис 46, основной государственный регистрационный номер: 1166733076608, номер телефона: +79203158381, адрес электронной почты: privoigrand@gmail.com

в лице Директора Шеста Александр Иосифовича
заявляет, что Электродвигатели (мотор-редукторы) асинхронные трехфазные общепромышленного назначения, рабочее напряжение 220/380В. Модели по приложению № 1, количество листов: 2 приложения, рабочее напряжение и адрес места осуществления деятельности по изготовлению продукции: Via Le Ghiselle, 20 25014 Castenedolo (BS), Италия.
Производство изготовлена в соответствии с Декретной 2014/35/EU "Титановольное оборудование".
Код ТН ВЭД ЕАЭС: 8501. Сериальный выпуск.

соответствует требованиям
ТР ТС 004/2011 "О безопасности низковольтного оборудования", утвержден Решением Комиссии Таможенного союза от 16 августа 2011 года № 768

Декларация о соответствии принята на основании
Протокола испытаний № 199-04/2020 от 14.04.2020 года, выданного Испытательной лабораторией Общества с ограниченной ответственностью Инновационный центр «Колibri», аттестат аккредитации РОСС RU.31857.0411.С.00063, сроком действия до 17.06.2022 года.

Схема декларирования 1а

Дополнительная информация
ГОСТ 16264.1-2016 Двигатели асинхронные. Часть 1. Общие технические условия. Срок хранения (службы, годности) указан в приложении к продукции товаросопроводительной и/или эксплуатационной документации.

Декларация о соответствии действительна с даты регистрации по 13.04.2025 включительно

Шеста Александр Иосифович
(ИПЧ заявителя)

Регистрационный номер декларации о соответствии: ЕАЭС N RU.Д-Т.ИХ37.В.02083/20
Дата регистрации декларации о соответствии: 14.04.2020

EAC MARKING

The EAC certificate of conformity (EurAsian Conformity) indicates that Motive motors meet all the applicable technical regulations of the Eurasian Customs Union and that they can therefore be sold on the territory of the acceding countries (Russia, Belarus, Kazakhstan, Armenia and Kyrgyzstan)

The mark  can consequently be found on the nameplate of Motive three-phase motors

MARINE MOTORS CERTIFIED BY RINA



In 2015 motive was admitted to the alternative test scheme (Certificate No. 2015 / MI / 01/537), which allows a more rapid and economical testing of three-phase marine motors compliant with RINA standards, both for essential service and not essential service.

In 2019 RINA also released the type design and validation tests certification for motive marine motors. In many cases this FREE certification is sufficient for the final customer, and therefore avoids the need to face the costs of the RINA test of each motor unit.

СИСТЕМА ДОБРОВОЛЬНОЙ СЕРТИФИКАЦИИ
«Старт»
Зарегистрирована в Едином реестре систем добровольной сертификации Федерального агентства по техническому регулированию и метрологии Российской Федерации (Росстандарт РФ)

ПРОФИСЕРТ

ИСПЫТАТЕЛЬНАЯ ЛАБОРАТОРИЯ ОБЩЕСТВО С ОГРАНИЧЕННОЙ ОТВЕТСТВЕННОСТЬЮ ИННОВАЦИОННЫЙ ЦЕНТР «КОЛИБРИ» (ООО ИЦЦ «КОЛИБРИ») 109025, г. Москва, 8-й проезд Марьиной Рощи, дом 30, стр. 1, тел. +7(499) 391-23-57, info@icc-ru.ru

АТТЕСТАТ АККРЕДИТАЦИИ № РОСС RU.31857.0411.С.00063 действителен до 17.06.2022г.

ПРОТОКОЛ ИСПЫТАНИЙ № 199-04/2020 от 14.04.2020 года

Место проведения испытаний:	Испытательная лаборатория ООО ИЦЦ «КОЛИБРИ»
Наименование продукции:	Общество с ограниченной ответственностью «ПРИВОД ГРАНД РЕДУКТОР» Федерация, Смоленская область, 214004, город Смоленск, улица Багратиона, дом 4, офис 46
Наименование продукции:	Электродвигатели (мотор-редукторы) асинхронные трехфазные общепромышленного назначения, рабочее напряжение 220/380В. Модели по приложению № 1, количество листов: 2 приложения, рабочее напряжение и адрес места осуществления деятельности по изготовлению продукции: Via Le Ghiselle, 20 25014 Castenedolo (BS), Италия.
Испытатель:	«Мotive srl». Место нахождения и адрес места осуществления деятельности: Via Le Ghiselle, 20 25014 Castenedolo (BS), Италия.
Ссылочный регламент:	ТР ТС 004/2011 "О безопасности низковольтного оборудования", Италия.
Испытания, согласно требованиям:	ТР ТС 004/2011 "О безопасности низковольтного оборудования", Италия.
Дата окончания срока:	31.03.2025г.

Пастовский Артём Викторович
Исполнительный директор

RINA

STATEMENT No. 2015/MI/01/537

On the basis of the examination of the documentation submitted, and following the satisfactory outcome of the inspection carried out, it is hereby stated that:

Name of the Manufacturer: **MOTIVE Srl**
Address: **Via Le Ghiselle, 20 - 25014 Castenedolo (Brescia, Italy)**

is admitted to the **Alternative Testing Scheme**, according to the "RINA Rules for Testing and Certification of Marine Materials and Equipment" for

Product: **ELECTRIC MOTORS**

at the following conditions:

- Inspections and tests during production and on finished products are to be performed in compliance with the production Quality Control Plan doc. no. 04 approved by RINA.
- The Manufacturer is to perform the inspections and tests required by the RINA Rules, to issue the certificate of conformity and mark the products with the stamp 

Periodical audits at Manufacturer premises, according to the schedule included in the attachment to this statement, are satisfactorily carried out by RINA.

This certificate is valid until **26 July 2020**

Issued at **Vimercate** on **27/07/2015**

This certificate consists of this sheet plus an attachment

RINA

RINA Services S.p.A.
Via Corridio, 12 - 16128 Genova
Tel. +39 010 52451
Fax +39 010 5201000

RINA

TYPE APPROVAL CERTIFICATE
No. ELEB12624CS

This is to certify that the product below is found to be in compliance with the applicable requirement of the RINA type approval system.

Description Type Applicant	Electric motor asynchronous three-phases DELPHI Series MOTIVE SRL VIA GHISELLE, 20 25014 Castenedolo (BS) ITALY
Manufacturer Place of manufacture	MOTIVE SRL VIA GHISELLE, 20 25014 Castenedolo (BS) ITALY
Reference standards	ITALY RINA Rules, Part C, Chap. 2, Sect. 4

Issued in **Genoa** on **April 23, 2024**. This Certificate is valid until **April 22, 2029**

RINA Services S.p.A.
Luigi Benedetti

This certificate consists of this page and 1 enclosure

RINA Services S.p.A.
Via Corridio, 12 - 16128 Genova
Tel. +39 010 52451
Fax +39 010 5201000

Digitally signed by RINA Services S.p.A. on 23 Apr 2024. No handwritten signature is provided.

RINA is a member of IACS, thus complying with the rules harmonized by the 12 members of IACS (ABS American Bureau of Shipping; Bureau Veritas, CCS China Classification Society; CRS Croatian Register of Shipping; DNV-GL, ICLASS Indian Register of Shipping; KR Korean Register of Shipping; Lloyd's Register; ClassNK Nippon Kaiji Kyokai; Polish Register of Shipping; Russian Maritime Register of Shipping)

(source: <http://www.iacs.org.uk/Explained/members.aspx>)

MOTIVE MOTORS PROTECTION

Protections must be chosen based on the specific running conditions, according to standards EN 60204-1

External protections

- Protection against overloads. A thermal cut-out relay, which automatically controls a knife switch.
- Protection against peak currents by magnetic relay that controls an automatic knife switch, or by fuses; these must be set to the locked rotor current.
- If the application requires, protection against excessive speed of the electric motor, for example if the mechanical load may drive the electric motor itself and thereby create a hazardous situation.
- If special conditions or synchronised operation with other machines or parts of machines require it, protection against power failures or dips by means of a minimum voltage relay that controls an automatic power knife switch.

Inner thermal overload cut-out switches (per CEI 2-3/IEC 34-1)

The electrical protections on the motor power line may not be sufficient to protect against overloads. If the cooling conditions worsen, the motor overheats but the electrical conditions do not change, which inhibits line protections. Installing built-in protections on the windings solves this problem:

● bimetallic device "PTO"



this is a normally-closed electromechanical device that opens when the threshold temperature is reached; it automatically

resets when the temperature falls below the threshold level. Bimetallic devices are available with various intervention temperatures and without automatic reset, per EN 60204-1.

● PTC thermistor device



this device promptly, positively adjusts its resistance once the threshold temperature is reached.

Motive motors from size 160 to size 355L are equipped as standard with 3 PTC thermistors immersed in the winding.

● PT100 device



using electronic

this is a device that continuously, increasingly adjusts its resistance according to the temperature. It is useful for constant measuring of the winding temperatures

● SCHEDAPT motor thermal probes PTC+PT100 control card / interface

SCHEDAPT is capable of reading PTC thermistors or up to 3 PT100 probes, both for winding and for bearings

It allows to constantly monitor the motor temperature by reading the PT100 and/or PTC temperature probes inside the motor and to provide an output contact N.C. (normally closed by default) which, connected in series to the power supply of the external line contactor, will stop the power supply of the motor at an alarm temperature (130°C default setting by motive for PT100, editable, and PTC according to its own data) The casing, simple and compact, allows this device to be mounted on a DIN rail. Supply voltage: 5 ÷ 30Vdc max 100mA.



DUTY SERVICE

All Motive motors shown in this catalogue are made for S1 continuous duty service, as per IEC 34-1 norm. The duty service class is shown on the rating plate.

Below are described the various types of service:

S1 - Continuous service: operating at constant load of duration N in order to reach a thermal balance.

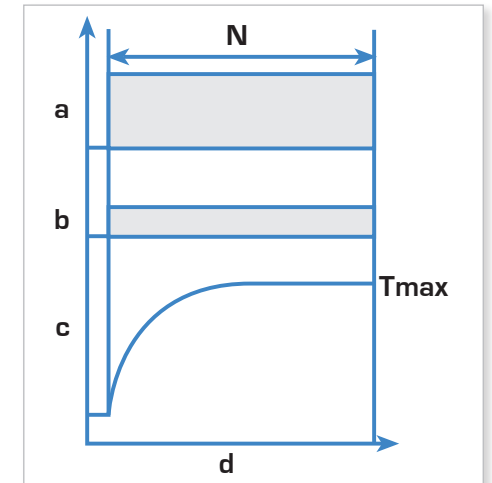

- a = load
- b = electric losses
- c = temperature
- d = time
- N = steady load operating time
- Tmax = max temperature achieved

S2 - Limited-duration service.

S3 - Periodic intermittent service.

S4 - Periodic intermittent service with startup.

S5 - Periodic intermittent service with electric braking.

S6 - Uninterrupted periodic service with intermittent load.

S7 - Uninterrupted periodic service with electric braking.

S8 - Uninterrupted periodic service with correlated load and velocity variations.

S9 - Service with non-periodic variations in load and speed.

IP PROTECTION INDEX

The protection against people accidental contacts and/or the entry of corps and/or the entry of water is expressed at international level (EN60529) by a symbolic acronym composed by a group of 2 letters and 2 numbers.

IP index of protection reference letters

1° num. Protection of people against contacts and protection against the entry of solid corps

2° num. Protection against harmful entry of water

Motive motors are IP55 protected

	1° number	2° number
0	no protection	no protection
1	protection against solid corps bigger than 50mm	protection against vertical water drops
2	protection against solid corps bigger than 12mm	protection against water drops fall up to 15° of inclination
3	protection against solid corps bigger than a 2,5mm	protection against water drops up to 60° of inclination
4	protection against solid corps bigger than 1 mm	protection against water sprayed by all directions
5	protection against harmful dust deposits complete protection against the total penetration of dust	protection against water launched by a nozzle of 6,3mm D with a water capacity 12,5lt/min at a distance of maximum 3 mt for 3 min
6		protection against water projections similar to sea waves
7		protection from temporary submersion in water, up to 1 meter in depth

RAIN SHIELD OR CLEAN FLOW FAN COWL FOR TEXTILE INDUSTRY

For outdoor applications with V5 - V18 - V1 - V15 installation, we recommend to mount a rain shield. This configuration may also be used in textiles processing industry.

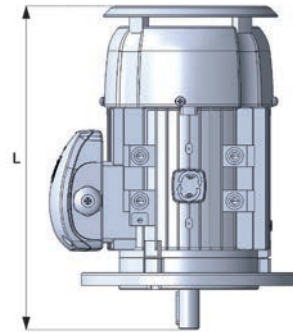

TYPE	L
63	215
71	323
80	369
90S	403
90L	428
100	469
112	453
132S	573
132M	613
160M	770
160L	825
180M	915
180L	955
200L	1025
225S	1155
225M	1160
250M	1220
280S	1265
280M	1315
315S	1540
315M	1570
315L	1680
355M	1840
355L	1870
400	2290



TOTAL SEALING

Resin coated stator is a safe solution to the presence of very strong humidity or aggressive environments (for instance, carwash systems or chemical plants). It offers also a lower heating thanks to the thermal dissipation capacity of the resin.

The ideal combination is the resin-filled terminal box. In this case, according to the customer needs, the terminal block can be partially immersed, or totally immersed in such insulating and protective resin. In alternative, the terminal box and block can be taken off and the motor frame be closed by a sealed plate from which a cable can come out.

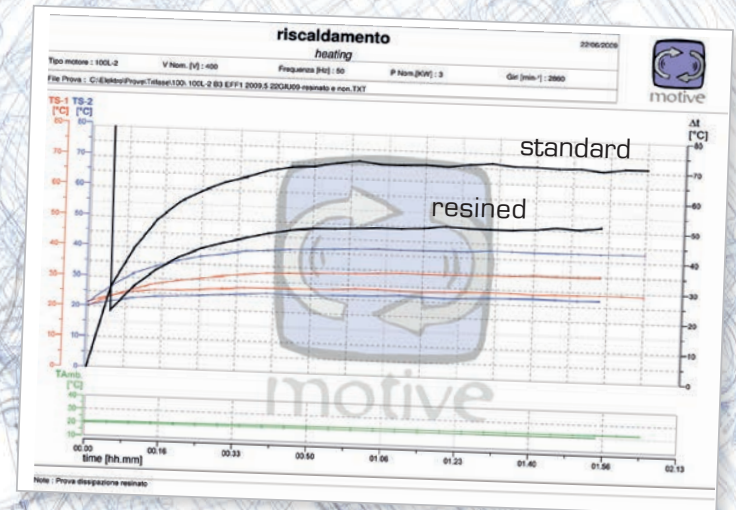

WORKING CONDITIONS

HUMIDITY:

The electrical equipment must be able to work with a relative humidity between 30 and 95% (without condensation). Damaging effects of occasional condensation must be avoided by adequate equipment design or, if necessary, by additional measures (for example, Motive offers anti-condensation heaters, drain holes, resin coated stators, and resin filled terminal boxes).

ALTITUDE AND TEMPERATURE:

the powers indicated are intended for regular use at altitudes below 1000 mt above sea level and a room temperature between + -15°C and +40°C (+100°C for delfire series) for motors having a rated power equal to or greater than 0.6 kW (IEC 34-1): For working conditions rather than those specified (higher altitude and/or temperature) the power decreases of 10% each 10°C of higher temperature, and of 8% for each 1000 mt of higher altitude.

It is not necessary to reduce the rated power if at an altitude higher than 1000mt and lower than 2000mt there is a max ambient temperature of 30°C or, in altitudes from 2000 mt to 3000mt there is a max ambient temperature of 19°C.

VOLTAGE - FREQUENCY:

The admitted variation of supply voltage and frequency is established by the norm EN60034-1. Within this tolerance delphi motors provide the rated power reported in the plate.

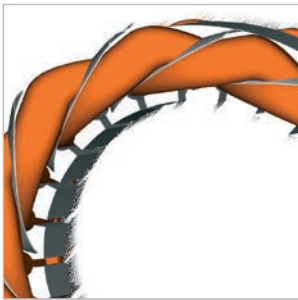

INSULATION:

The copper is impregnated with a double layer of H class insulating enamel to ensure high resistance to electrical, thermal and mechanical stress.

A NOMEX film that wraps entirely around the coil side insulates the copper and iron from one another.

The phases are further isolated by another layer of NOMEX to protect the motors from voltage peaks that usually occur when the motor is controlled by inverter.

In case that motors with more than 75kW are controlled by inverter, we suggest to request the electrically insulated bearing on the non drive end.

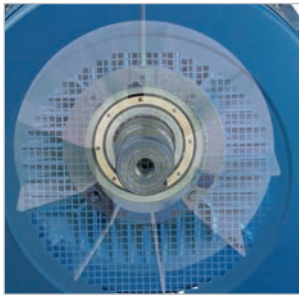

Its purpose is to open the electric circuit between the rotor and the motor frame, thus preventing that the shaft currents go through the bearings and damage their balls surface and roll tracks.

The section "technical data" of this catalogue shows the max operating temperatures according to the Class insulation shown on the plate.

Delphi motors are designed to conserve wide margins against eventual overloads, having a temperature rise that is, at rated power, much lower than the operating temperature limit given by their insulation class. This fact increases considerably the motors life length. Such "ΔT" values are evidenced in the following performance charts. (see further details about temperature rise in the "technical data" section of this catalogue)

ASSISTED POWER COOLING

For application with a power supply at certain frequencies (see following graph), a power cooling system (IC-416) must be used.

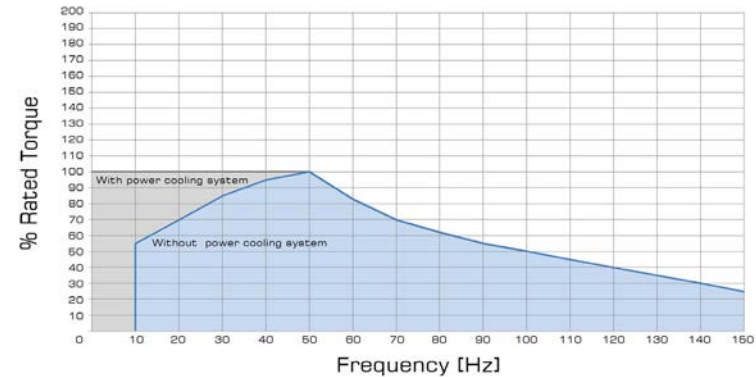

Motive power cooling systems are three-phase 400/50 400/60, IP 55, and with separate terminal box. "Upon request, single phase, ATEX, 24Vdc and special voltage power cooling systems are also available."

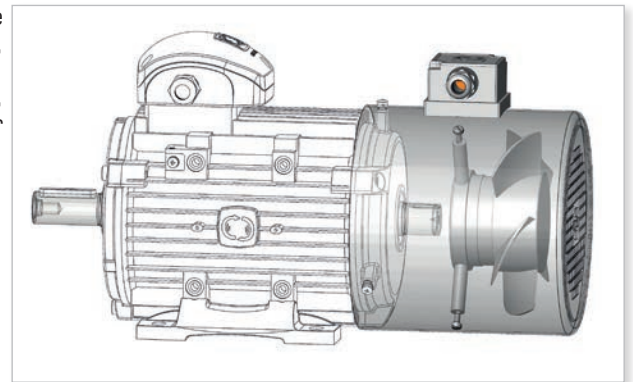

ENCODER

Motors with incremental, absolute, profinet, profibus and ATEX encoders are available upon request. In this case, assisted power cooling is also available.

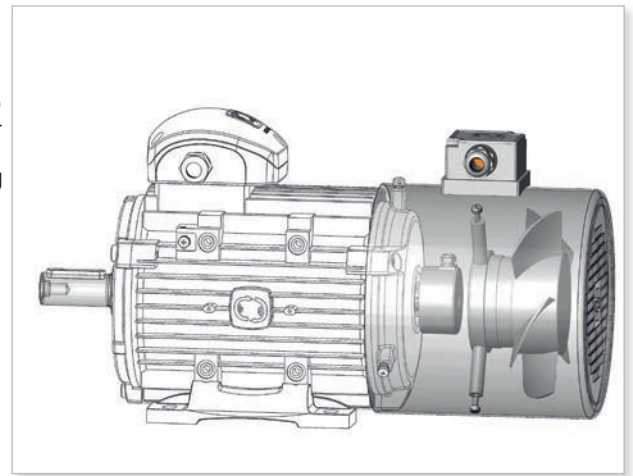

WIRING DIAGRAMS

Motive three phase motors can be connected "Star" or "Delta".

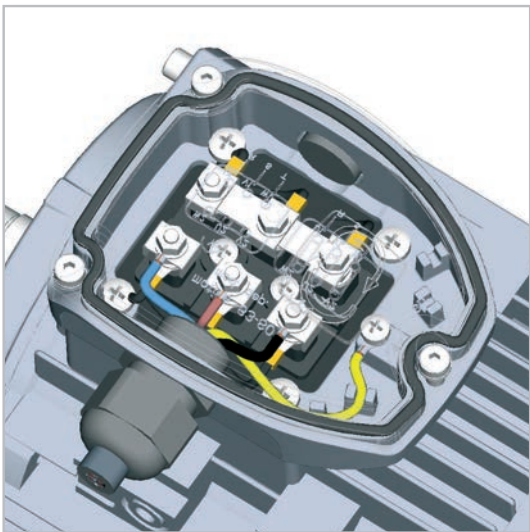

STAR CONNECTION

Star connection is obtained by connecting together the terminals W2, U2, V2 and supplying the terminals U1, V1, W1.

The phase current I_{ph} and the phase voltage U_{ph} are

$$I_{ph} = I_n$$

$$U_{ph} = U_n / 1,74$$

where I_n is the supply line current and U_n is the supply line voltage of Star connection

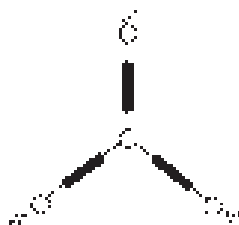

DELTA CONNECTION

Delta connection is obtained by connecting the end of a phase with the beginning of the following one.

The phase current I_{ph} and the phase voltage U_{ph} are respectively:

$$I_{ph} = I_n / 1,74$$

$$U_{ph} = U_n$$

where I_n and U_n are referred to Delta connection.

The star-delta start is the easiest way to reduce the current and the starting torque. The motors whose rated voltage in delta connection corresponds to the mains voltage can be started with the star-delta method

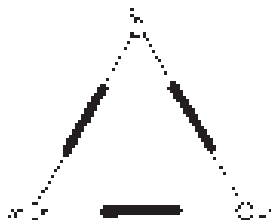
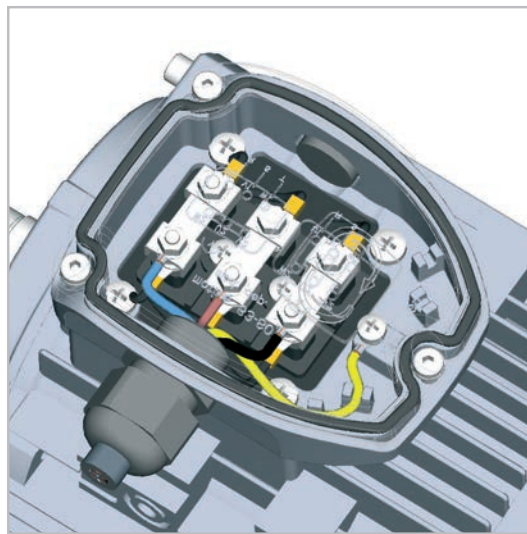

the following voltages and frequencies are inside the standard power supply of all motive 3PH motors, under S1 duty service:

Size	Hz	Volts	
56-132	50 ±5%	230	400
		220	380
		240	415
	60 ±5%	260	440
		220	380
		265	460
112-355	50 ±5%	280	480
		400	690
		380	660
	60 ±5%	415	720
		440	760
		380	660
		460	795
		480	830



For further wiring schemes with brake, 1PH, VFD, etc, download the manual from <https://www.motive.it/en/manuali.php>

THREE-PHASE SELF-BRAKING MOTORS SERIES DELPHI AT..

Delphi ATDC, AT24 and ATTD series self-braking motors use one or 2 spring-pressure brakes, firmly spliced onto a cast iron shield at the back of the motor.

These motors include a series of characteristics normally considered options by other brands, like:

- The standard hand lever permits to release the brake, making it possible to move manually the shaft,
- Thermal protectors embedded in the winding for all frame sizes.
- Easy separate connection of the brake in case that the motor is connected to an inverter.

On ATDC and ATTD, the separate brake power supply is achieved, whenever needed, by connecting directly to the brake terminal board located inside the motor terminal box.

On AT24, the 24Vdc single or double brakes are designed to be directly connected to an inverter (usually having a 24Vdc plug)

On request, the brakes can be modified to be extremely silent for usage in special environments like theatres

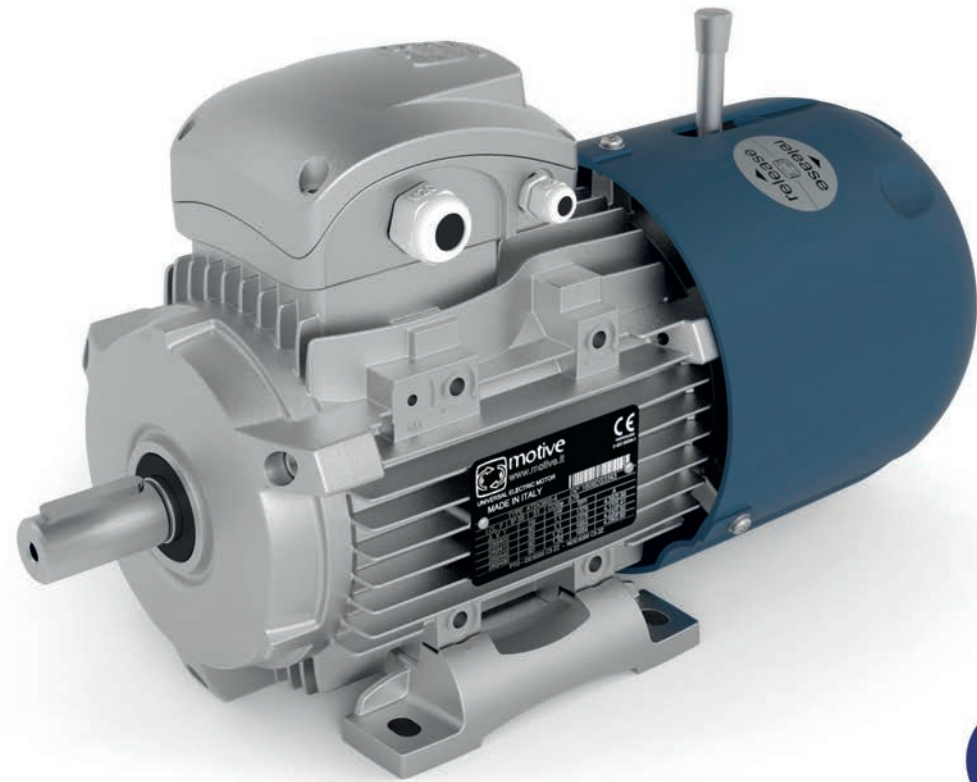

IE2, high efficiency class IEC 60034-30-1

IE3, premium efficiency class IEC 60034-30-1

IE4, super premium efficiency class IEC 60034-30-1

The standard version has an IP55 protection index. Also available in IP56, IP65, and IP66 versions.

IEC Type	ATDC						AT24				ATDC AT24	ATTD
	Static max braking torque [Nm]	standard vers. braking time no-load [Sec]	"TA version" braking time no-load [Sec]	input voltage on rectifier [Vac]	output voltage to brake [Vdc]	brake power [W]	Static max braking torque [Nm]	Static min braking torque [Nm]	Braking time no-load [Sec]	brake power [W]	extra Kg on std	extra Kg on std
AT..63	4,5	0,15	<0,05	220-280 (opt. 380-480)	99-126 (opt. 171-216)	20	4,5	4,0	0,06	20	+4	+7,5
AT..71	8,0	0,15	<0,05	220-280 (opt. 380-480)	99-126 (opt. 171-216)	28	4,5	4,0	0,06	20	+5	+9
AT..80	12,5	0,20	<0,05	220-280 (opt. 380-480)	99-126 (opt. 171-216)	30	10,0	9,0	0,09	25	+5,5	+10
AT..90	20,0	0,25	<0,05	220-280 (opt. 380-480)	99-126 (opt. 171-216)	45	16,0	12,0	0,11	45	+6	+11
AT..100	38,0	0,30	<0,05	220-280 (opt. 380-480)	99-126 (opt. 171-216)	60	32,0	28,0	0,14	60	+7	+12,5
AT..112	55,0	0,35	<0,05	380-480	171-216	65	60,0	55,0	0,15	65	+10	+19
AT..132	90,0	0,40	<0,05	380-480	171-216	90	90,0	80,0	0,16	85	+12	+23
AT..160	160,0	0,50	<0,05	380-480	171-216	110	160,0	130,0	0,21	105	+22	+42
AT..180	250,0	0,50	<0,05	380-480	171-216	130					+32	+62
AT..200	420,0	0,50	<0,05	380-480	171-216	140					+40	+77
AT..225	450,0	0,50	<0,05	380-480	171-216	160					+52	+100
AT..250	550,0	0,50	<0,05	380-480	171-216	170					+80	+155
AT..280	900,0	0,50	<0,05	380-480	171-216	360					+106	+209
ATTD	ATTD= ATDCx2					ATTD= ATDCx2						

ATDC

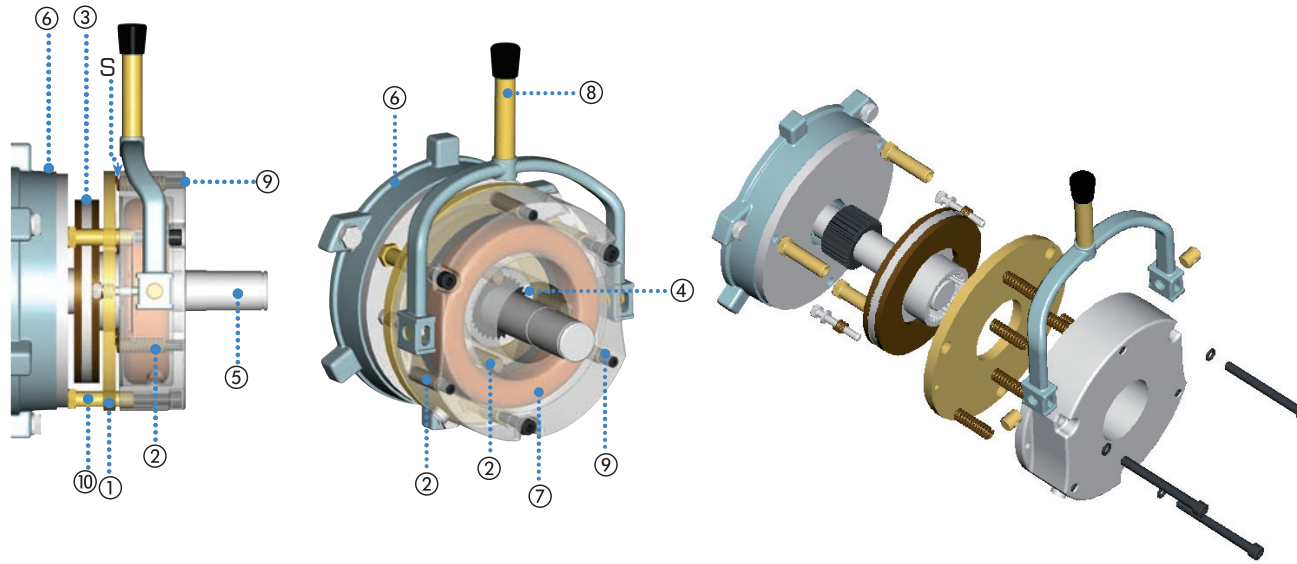

- ① Mobile armature
- ② springs
- ③ Brake disc
- ④ Driver
- ⑤ Motor shaft
- ⑥ Motor flange
- ⑦ Electromagnet
- ⑧ Release lever
- ⑨ Adjuster screws
- ⑩ Threaded bush
- ⑪ braking torque setting knob
- ⑫ ATTD connection plate

S Air gap

BRAKE DESCRIPTION

The delphi AT.. series brakes are electromagnetic brakes with negative operation, whose braking action is exercised in the absence of power supply.

The brakes insulation class is F. The brakes lining is asbestos-free. The rectifier is of relays type, with protection varistors at the entry and the exit. All brake assemblies are protected against corrosion by painting or heat galvanizing and resined winding. The parts most subject to wear are treated in special atmospheres that provide considerable wear resistance to the parts.

BRAKE OPERATION

When the power supply is interrupted, the excitation coil ⑦ is no longer powered and therefore doesn't exert the magnetic force necessary to restrain the mobile armature ①, which, pushed by the pressure springs ②, compresses the brake disk ③ against the motor flange ⑥ on one side and the armature itself on the other, thereby creating a braking action.

AT24

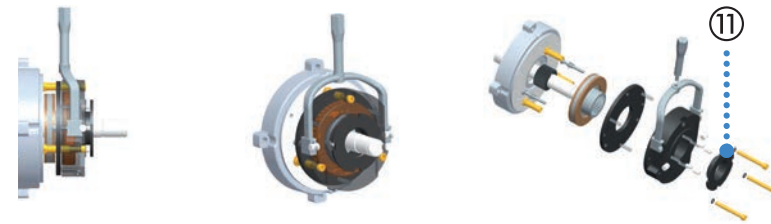

ATTD

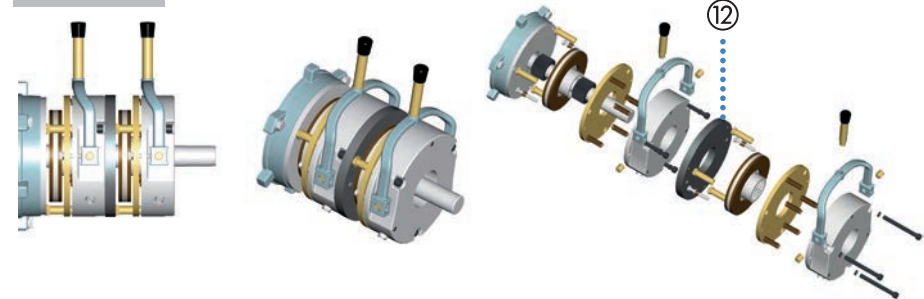

ADJUSTMENT

On ATDC and ATTD motors bigger than size 90, two different types of adjustment are possible (download the technical manual from <https://www.motive.it/en/manuali.php>)

The braking torque is set to its max level by Motive, but it can be decreased by acting on the adjuster screws ⑨ (ATDC and ATTD motors) or on the knob ⑪ (AT24). Brake adjustment is only possible from size 90 L to size 280.

MANUAL RELEASE

Motive brake motors are supplied with the manual release lever in their standard version. If not wished, the lever is like a screw, that can be taken away simply turning it. ATTD tandem brake motors, from size 180 up to sized 280, cannot have the manual release.

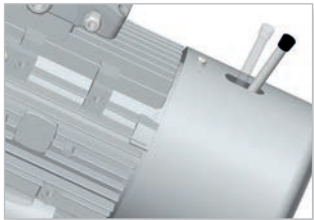

AT.. brakes are IP55 under an electrical point of view, but mechanically, in case of an outdoor use, they should be protected by rust and by disc adhesion effects given by humidity. It is also available in IP65, IP56, and IP66 versions.

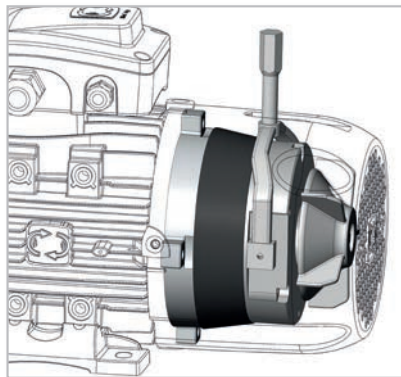

IP

POWER SUPPLY

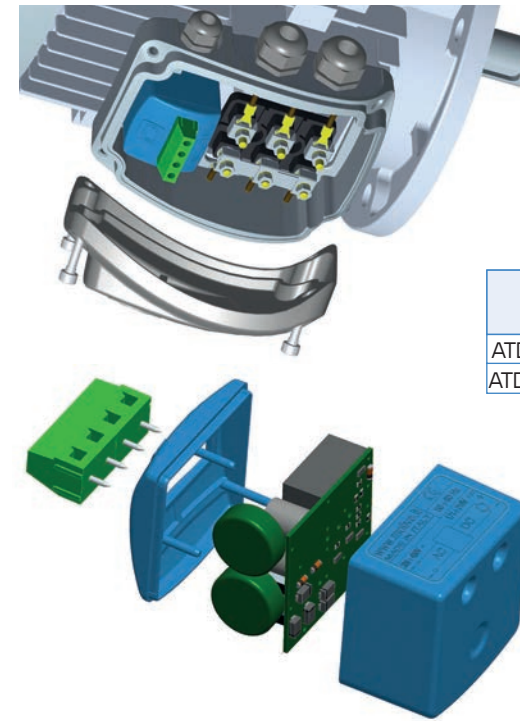

ATDC brakes are DC brakes power supplied by a rectifier installed inside the motor main terminal box.

The following tablechart shows the tensions on the rectifier and the brake of ATDC model

ATDC model	input voltage on rectifier [Vac]	output voltage to the brake [Vdc]
ATDC 63-100	220-280	99-126
ATDC type 280	380-480	162-216

Unless there's a different request of the client, motive supplies ATDC brake motors with the rectifier already connected directly to the main terminal block of the motor (fig. 1 and 2), in order to permit to the motor switching to act at the same time on the brake.

STAINLESS STEEL BRAKING SURFACE

MICRO-SWITCHES TO DETECT BRAKE POSITION

Upon request, where humidity and intermittent service may cause early oxidation of the contact surface between the rear shield and the brake disc, a stainless steel cover can be added to the part of the rear shield in contact with the brake pad.

Optional.

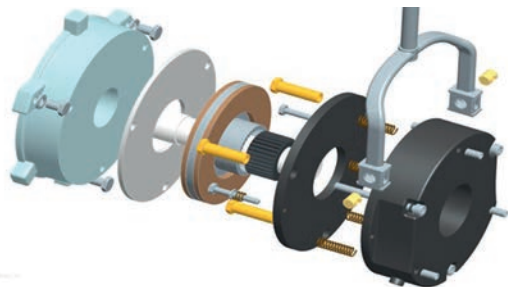
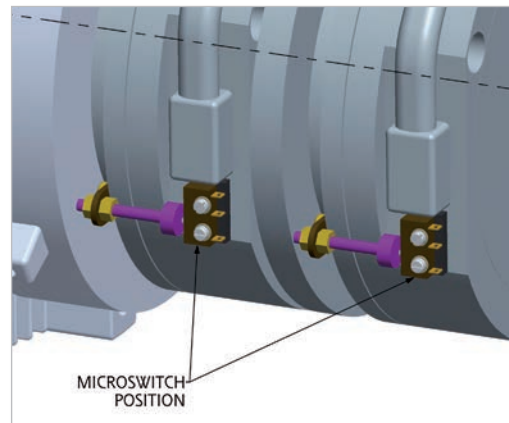

In case that the motor is power supplied by a frequency inverter (fig. 3), or at a special voltage*, or at a low tension during the start, or in case that the motor is used to move loads which can have an inertial movement, like lifted weights (such inertial movement can move the motor when the power is switched off, and the motor can act like a generator on the rectifier avoiding the brake locking), disconnect the motor main terminal board from the rectifier, and connect separately the rectifier (ATDC) (fig. 3 and 4).

TA special rectifier permits to solve the problem of inertial movements with no need for a separate power supply to the rectifier (fig 2)

This exclusive rectifier offers the following innovations:

- double semi-wave technology.
- special vibration proof 6 Ampere relays (like the ones used on Ducati race motorbikes).
- electric arcs ultra resistant contacts in silver alloy.
- relays system instead of normal mosfets system, thus more resistant against tension peaks, even if impulsive.
- an in-built current reading system which controls the current sinusoid and the relay commutation time.

What's the advantage? Rectifier is normally the "brain" and the fragile point of any dc brake motor. This rectifier is stronger against disturbs coming from power line, much stronger than what required by European EMC rules for industrial environment; they are more resistant against

ATDC  400Vac/180Vdc rectifier (fig. 1)

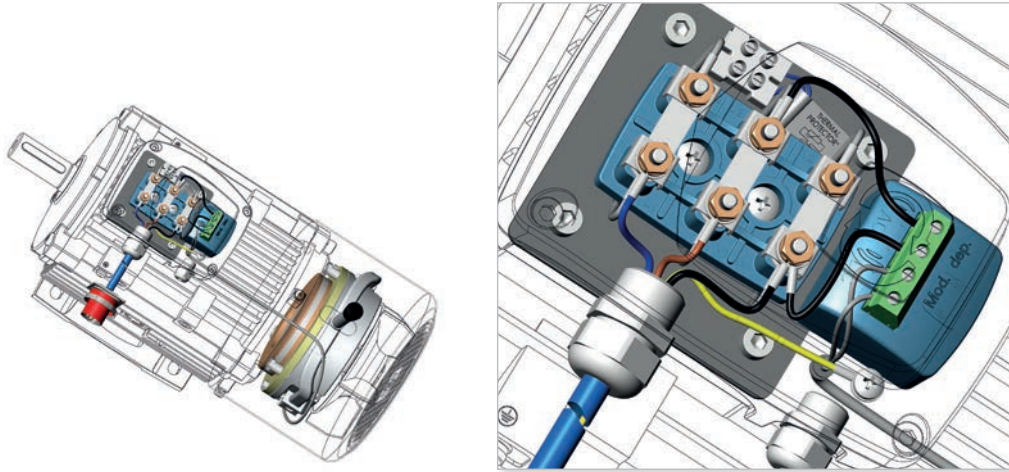

ATDC  400Vac/180Vdc TA rectifier (fig. 2)

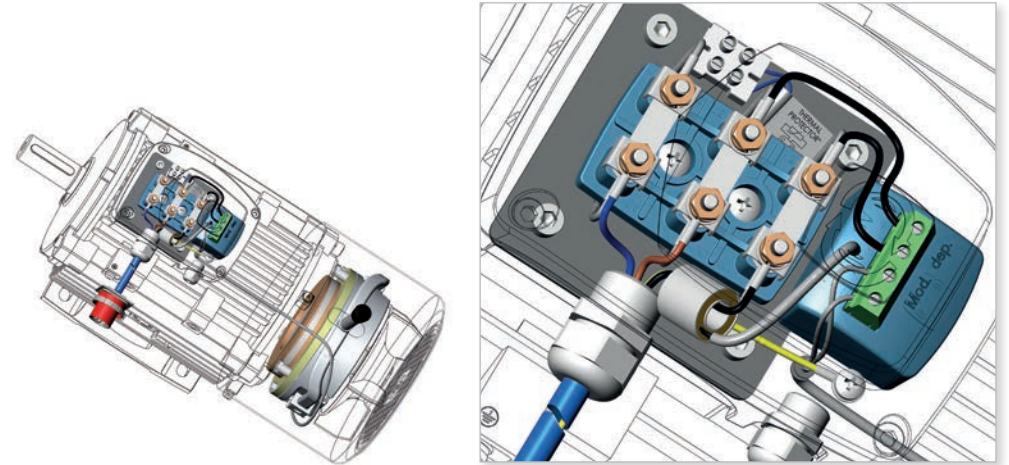

ATDC  (separate 400Vac/180Vdc rectifier) + inverter (fig. 3)

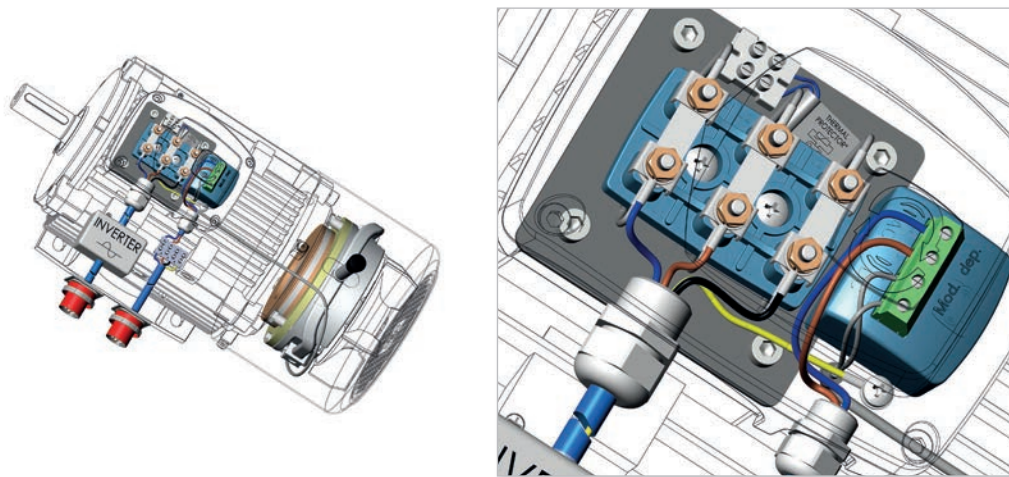

ATDC  + separate 400Vac/180Vdc rectifier connection (fig. 4)

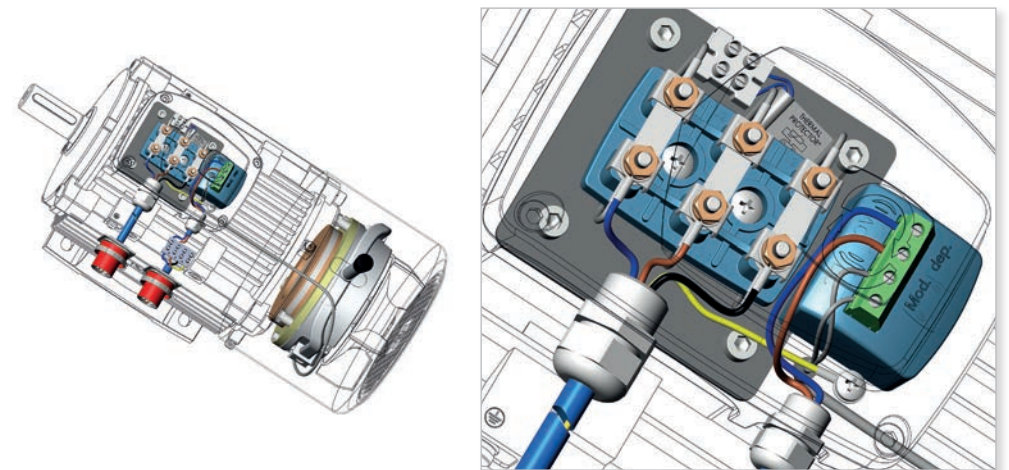

Configure what you need by this automatic consultant, and get CAD files and data sheets

Motive configurator allows you to shape Motive products, combine them as you want, and finally to download 2D/3D CAD drawings, and a PDF datasheet.

Search by performance

If you're not sure about the best products combination that you should select for your purpose, you can input your wishes, like final torque, final speed, use, etc, and the configurator will act like a consultant.

It will give you a list of applicable product configurations; you can then download a PDF data sheet featuring performance data and dimensional drawings for each configuration, as well as 2D and 3D drawings.

Search by product







To be used if you already know the product configuration that you want, and you just want to get quicker a PDF data sheet featuring performance data and dimensional drawings for 2D and 3D drawings.

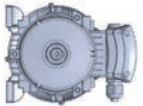
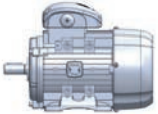
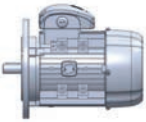
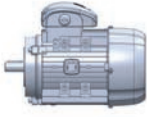
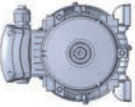
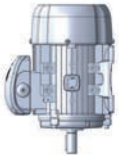
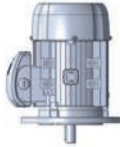
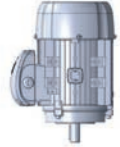
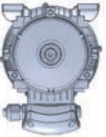

free access without login
<http://www.motive.it/configuratore.php>

CONSTRUCTION FORMS AND SIZE TABLES

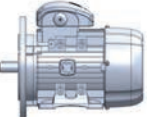
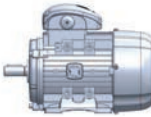
MOTOR CONFIGURATIONS AND INSTALLATION POSITIONS (IEC 34-7)

MOTORS WITH FEET B3		FLANGE-MOUNTED MOTORS B5	FLANGE-MOUNTED MOTORS B14
 IM1051 (IM B6)	 IM1001 (IM B3)	 IM3001 (IM B5)	 IM3601 (IM B14)
 IM1061 (IM B7)	 IM1011 (IM V5)	 IM3011 (IM V1)	 IM3611 (IM V18)
 IM1071 (IM B8)	 IM1031 (IM V6)	 IM3031 (IM V3)	 IM3631 (IM V19)
B3/B5  IM2001 (IM B35)	B3/B14  IM2101 (IM B34)	V1/V5  IM2011 (IM V15)	V3/V6  IM2031 (IM V36)

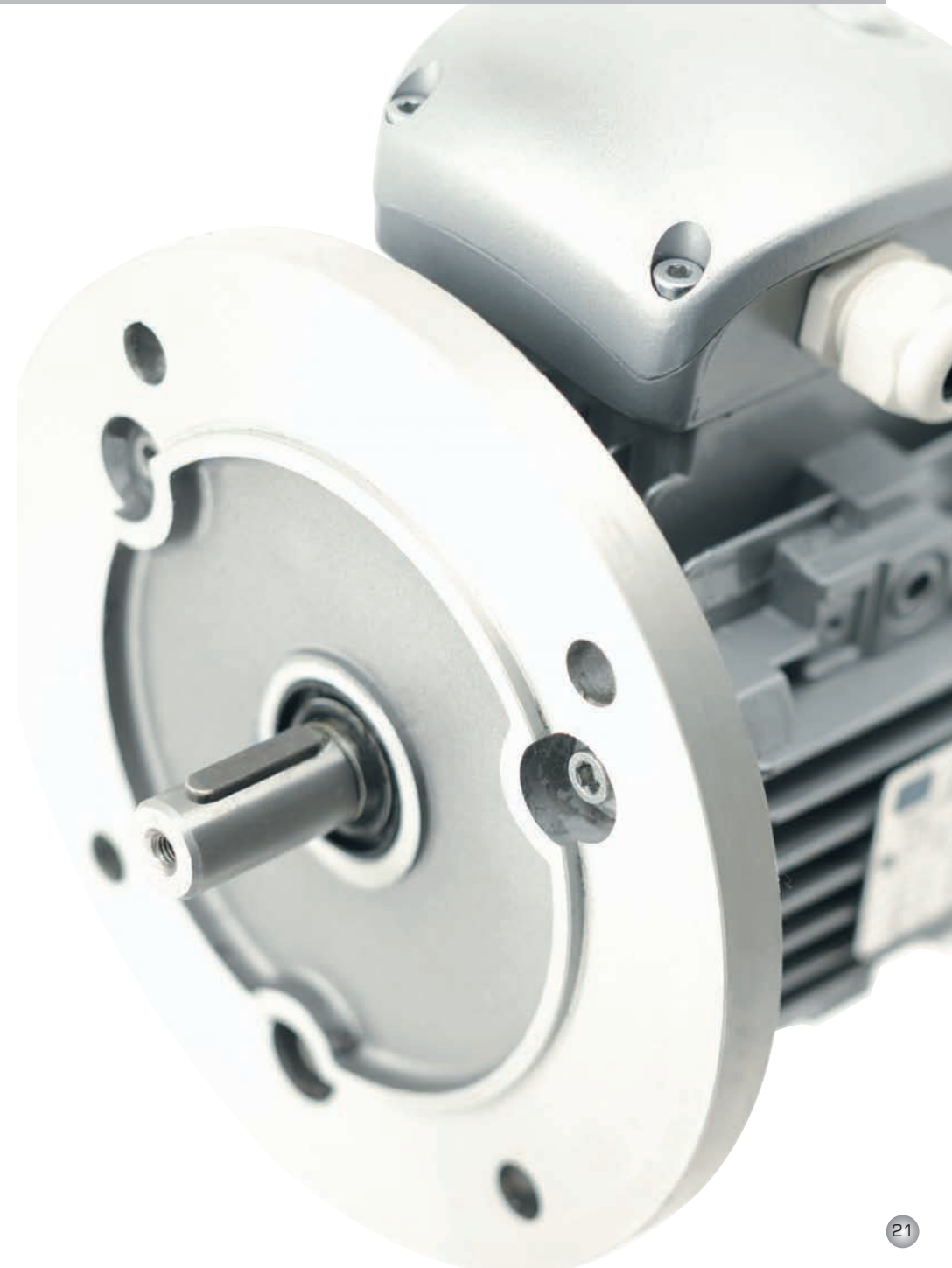

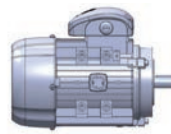
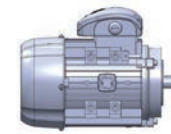
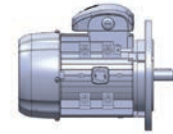
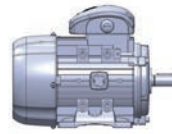

TYPE	POLES	AD	AD	H	KK	L	IE2	IE3/IE4	B3								B5					B14					B5R / B14B									
							L	D	DH	E	Q	F	G	A	AB	B	C	K	M	N	P	R	S	T	M	N	P	R	S	T	M	N	P	R	S	T
56	2-8	102	-	56	M16	198	-	9	M4x12	20	3	3	7,2	90	111	71	36	5,8	100	80	120	0	7x4	3	65	50	80	0	M5	2,5	-	-	-	-	-	-
63	2-8	107	116	63	M20	215	-	11	M4x12	23	3	4	8,5	100	123	80	40	7	115	95	140	0	10x4	3	75	60	90	0	M5	2,5	100	80	120	0	M6	2,5
71	2-8	119	124	71	M20	244	-	14	M5x12	30	3	5	11,0	112	138	90	45	7	130	110	160	0	10x4	3,5	85	70	105	0	M6	2,5	115	95	140	0	M8	3,0
80	2-8	130	139	80	M20	283	283	19	M6x16	40	3	6	15,5	125	157	100	50	10	165	130	200	0	12x4	3,5	100	80	120	0	M6	3,0	130	110	160	0	M8	3,5
90S	2-8	145	146	90	M20	310	330/330	24	M8x19	50	5	8	20,0	140	173	100	56	10	165	130	200	0	12x4	3,5	115	95	140	0	M8	3,0	130	110	160	0	M8	3,5
90L	2-8	145	146	90	M20	338	358/358	24	M8x19	50	5	8	20,0	140	173	125	56	10	165	130	200	0	12x4	3,5	115	95	140	0	M8	3,0	130	110	160	0	M8	3,5
100	2-8	157	161	100	M20	373	393/393	28	M10x22	60	5	8	24,0	160	196	140	63	12	215	180	250	0	15x4	4	130	110	160	0	M8	3,5	165	130	200	0	M10	3,5
112M	2-8	177	177	112	M25	390	410/410	28	M10x22	60	5	8	24,0	190	227	140	70	12	215	180	250	0	15x4	4	130	110	160	0	M8	3,5	165	130	200	0	M10	3,5
132S	2-8	197	195	132	M32	460	480	38	M12x28	80	5	10	33,0	216	262	140	89	12	265	230	300	0	15x4	4	165	130	200	0	M10	3,5	215	180	250	0	M10	4,0
132M	2-8	197	195	132	M32	496	516	38	M12x28	80	5	10	33,0	216	262	178	89	12	265	230	300	0	15x4	4	165	130	200	0	M10	3,5	215	180	250	0	M10	4,0
160M	2-8	255	255	160	2xM40	613	613	42	M16x36	110	5	12	37,0	254	320	210	108	15	300	250	350	0	19x4	5	215	180	250	0	M12	4,0	265	230	300	0	14x4	5,0
160L	2-8	252	252	160	2xM40	708	708	42	M16x36	110	5	12	37,0	254	320	254	108	15	300	250	350	0	19x4	5	215	180	250	0	M12	4,0	265	230	300	0	14x4	5,0
180M	2-8	270	270	180	2xM40	730	730	48	M16x36	110	8	14	42,5	279	355	241	121	15	300	250	350	0	19x4	5												
180L	2-8	270	270	180	2xM40	780	780	48	M16x36	110	8	14	42,5	279	355	279	121	15	300	250	350	0	19x4	5												
200L	2-8	303	303	200	2xM50	771	771	55	M20x42	110	12	16	49,0	318	395	305	133	19	350	300	400	0	19x4	5												
225S	2-8	312	312	225	2xM50	815	815	60	M20x42	140	12	18	53,0	356	435	286	149	19	400	350	450	0	19x8	5												
225M	2	312	312	225	2xM50	820	820	55	M20x42	110	12	16	49,0	356	435	286/311	149	19	400	350	450	0	19x8	5												
225M	4-8	312	312	225	2xM50	850	850	60	M20x42	140	12	18	53,0	356	435	286/311	149	19	400	350	450	0	19x8	5												
250M	2	355	355	250	2xM63	910	910	60	M20x42	140	12	18	53,0	406	490	349	168	24	500	450	550	0	19x8	5												
250M	4-8	355	355	250	2xM63	910	910	65	M20x42	140	12	18	58,0	406	490	349	168	24	500	450	550	0	19x8	5												
280S	2	398	398	280	2xM63	985	985/985	65	M20x42	140	12	18	58,0	457	550	368	190	24	500	450	550	0	19x8	5												
280S	4-8	398	398	280	2xM63	985	985/985	75	M20x42	140	12	20	67,5	457	550	368	190	24	500	450	550	0	19x8	5												
280M	2	398	398	280	2xM63	1035	1035/1035	65	M20x42	140	12	18	58,0	457	550	368/419	190	24	500	450	550	0	19x8	5												
280M	4-8	398	398	280	2xM63	1035	1035/1035	75	M20x42	140	12	20	67,5	457	550	368/419	190	24	500	450	550	0	19x8	5												
315S	2	540	-	315	2xM63	1160	1160/1160	65	M20x42	140	15	18	58,0	508	630	406	216	28	600	550	660	0	24x8	6												
315S	4-8	540	-	315	2xM63	1270	1270/1270	80	M20x42	170	15	22	71,0	508	630	406	216	28	600	550	660	0	24x8	6												
315M	2	540	-	315	2xM63	1290	1290/1290	65	M20x42	140	15	18	58,0	508	630	457	216	28	600	550	660	0	24x8	6												
315M	4-8	540	-	315	2xM63	1325	1325/1325	80	M20x42	170	15	22	71,0	508	630	457	216	28	600	550	660	0	24x8	6												
315L	2	540	-	315	2xM63	1320	1320/1320	65	M20x42	140	15	18	58,0	508	630	508	216	28	600	550	660	0	24x8	6												
315L	4-8	540	-	315	2xM63	1350	1350/1350	80	M20x42	170	15	22	71,0	508	630	508	216	28	600	550	660	0	24x8	6												
355M	2	655	-	355	2xM63	1500	1500/1500	75	M20x42	140	15	20	67,5	610	730	560/630	254	28	740	680	800	0	24x8	6												
355M	4-8	655	-	355	2xM63	1530	1530/1530	95	M20x42	170	15	25	86,0	610	730	560/630	254	28	740	680	800	0	24x8	6												
355L	2	655	-	355	2xM63	1500	1500/1500	75	M20x42	140	15	20	67,5	610	730	560/630	254	28	740	680	800	0	24x8	6												
355L	4-8	655	-	355	2xM63	1530	1530/1530	95	M20x42	170	15	25	86,0	610	730	560/630	254	28	740	680	800	0	24x8	6												

For the dimensional data of delfire series, ask to our commercial office.

TYPE	POLES	SV IE2	SV IE3/IE4	ATDC AT24	ATDC AT24 IE3/IE4	ATDC+DC AT24+DC	ATDC+DC AT24+DC IE3/IE4	ATTD	ATTD IE3/IE4	ATTD+SV	ATTD+SV IE3/IE4
		L	L	L	L	L	L	L	L	L	L
56	2-8	-	-	-	-	-	-	-	-	-	-
63	2-8	301	-	276	-	401	-	321	-	438	-
71	2-8	341	-	300	-	442	-	365	-	497	-
80	2-8	388	-	340	-	509	-	417	-	560	-
90S	2-8	420	440/440	385	411/411	566	592/592	465	491/491	577	603/603
90L	2-8	445	465/465	410	436/436	591	617/617	490	516/516	602	628/628
100	2-8	483	503/503	450	474/474	621	645/645	488	512/512	647	671/671
112M	2-8	525	545/545	475	505/505	668	698/698	563	593/593	693	723/723
132S	2-8	590	610	557	588	765	796	640	671	795	826
132M	2-8	625	645	590	621	803	834	677	708	832	863
160M	2-8	765	765	720	-	1009	-	820	-	929	-
160L	2-8	862	862	771	-	1104	-	882	-	1033	-
180M	2-8	860	860	847	-	990	-	995	-	1140	-
180L	2-8	910	910	888	-	1038	-	1044	-	1188	-
200L	2-8	973	973	890	-	1013	-	1050	-	1178	-
225S	2-8	955	955	935	-	1090	-	1115	-	1351	-
225M	2	955	955	935	-	1090	-	1115	-	1345	-
225M	4-8	985	985	965	-	1120	-	1145	-	1375	-
250M	2	1045	1045	1075	-	1211	-	1285	-	1466	-
250M	4-8	1045	1045	1075	-	1211	-	1285	-	1466	-
280S	2	1105	1105/1105	1175	-	1274	-	1355	-	1444	-
280S	4-8	1105	1105/1105	1175	-	1274	-	1355	-	1444	-
280M	2	1160	1160/1160	1230	-	1329	-	1410	-	1499	-
280M	4-8	1160	1160/1160	1230	-	1329	-	1410	-	1499	-
315S	2	1400	1400/1400								
315S	4-8	1430	1430/1430								
315M	2	1500	1500/1500								
315M	4-8	1530	1530/1530								
315L	2	1500	1500/1500								
315L	4-8	1530	1530/1530								
355M	2	1740	1740/1740								
355M	4-8	1770	1770/1770								
355L	2	1740	1740/1740								
355L	4-8	1770	1770/1770								



you can download 2D and 3D drawings from www.motive.it

B3

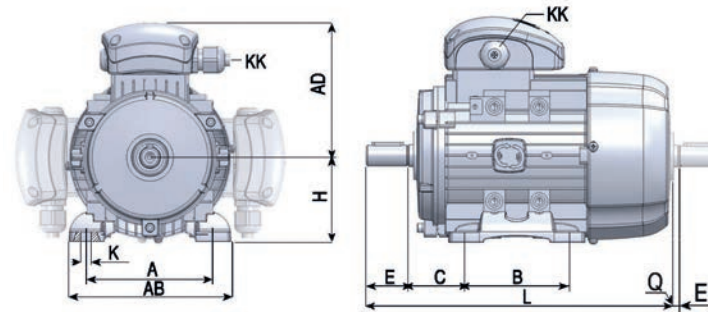

B5, B3/B5

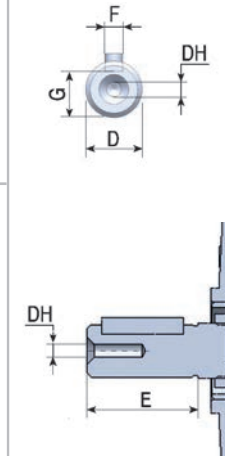
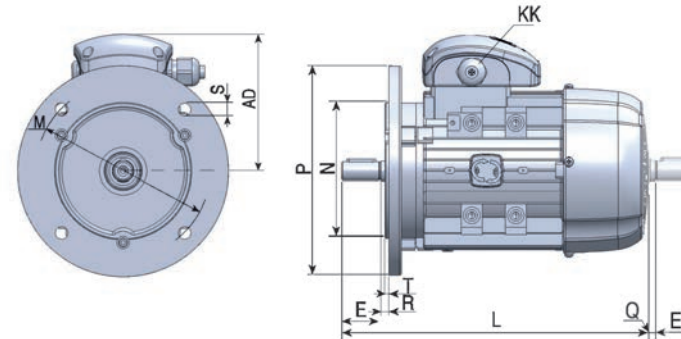

B14, B5R/B14B

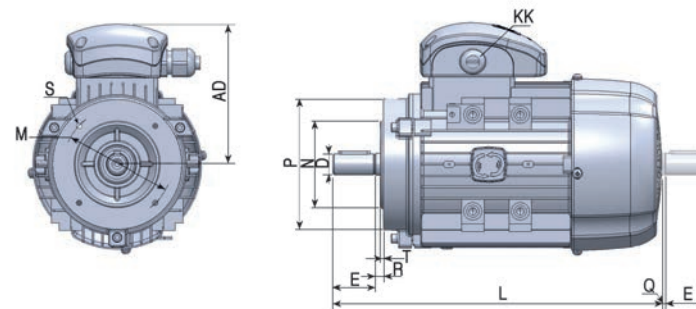

DATI TECHNICAL DATA

The general electrical specifications are listed in the performance charts that follow. To understand their contents, the following general definitions are provided.

Rated Power:
it is the mechanical power measured at the shaft expressed, according to the latest indications of international Standards Committees, in Watts or Kwatts. However, in the engineering sector it is still common to refer to power in terms of HP

Rated Voltage:
the voltage to be applied to the motor terminals in accordance with the specifications in the following tables

Frequency:
All electrical data in this catalogue refer to three-phase wound motors at 50 Hz. These may be connected to 60 Hz, taking into account the multiplier coefficients in the table below

rated voltage at 50Hz	Volt at 60Hz	rated power W	In (A)	Cn (Nm)	rpm	Is (A)	Cs (Nm)	Cmax (Nm)
230 ± 10%	230 ± 5%	1	1	0,83	1,2	0,83	0,83	0,83
230 ± 10%	230 ± 10%	1	0,95	0,83	1,2	0,83	0,83	0,83
230 ± 10%	240 ± 5%	1,05	1	0,87	1,2	0,87	0,87	0,87
400 ± 10%	380 ± 5%	1	1	0,83	1,2	0,83	0,83	0,83
400 ± 10%	400 ± 10%	1	0,95	0,83	1,2	0,83	0,83	0,83
400 ± 10%	415 ± 10%	1,05	1	0,87	1,2	0,87	0,87	0,87
400 ± 10%	440 ± 10%	1,10	1	0,90	1,2	0,93	0,93	0,93
400 ± 10%	460 ± 5%	1,15	1	0,96	1,2	0,96	0,96	0,96
400 ± 10%	480 ± 5%	1,20	1	1	1,2	1	1	1

for further information, see chapter "wiring diagrams"

Synchronous speed:
is expressed in rpm and it is obtained by the formula
 $f = 120/p$
f= supply frequency Hz
p= number of poles pairs

Rated Current:
"In" is the Rated Current, expressed in Ampere, absorbed by the motor when supplied at Rated Voltage Vn (V) and giving the Rated Power Pn (W) and it is obtained by the formula

$$I_n = \frac{P_n}{\sqrt{3} \cdot V_n \cdot \eta \cdot \cos\varphi} \text{ (A)}$$

In the following tables, the rated currents are referred to a Voltage supply of 400V. For other voltage supplies the absorbed rated current can be considered inversely proportional to the voltage supply. EX:

Volt	230	380	400	440	690
In	1,74	1,05	1,00	0,91	0,64

Motive motors can face also temporary overloads, with Current increases of 1.5 times the rated current for at least 2 minutes.

Starting current (or locked rotor current):
(you see diagram)

Rated torque:
Cn is expressed in Nm, and it corresponds to the rated power and rated rpm. It is given by the multiplication of the force for the arm (distance) and it is measured in Newton because the force is expressed in Newton and the distance in metres. The rated torque value is obtained by the formula
 $C_n \text{ (Nm)} = P_n \times 9550 / \text{rpm}$
Pn= Rated power in KW
rpm= rated rotation speed

Efficiency:
 η is expressed in % and it is given by the relation between the output Power and the addition of output Power and the electric losses of the motor, that is the input power absorbed by the motor. The electric motors losses are mainly of two kinds: for joule effect (rotor and stator) and iron losses.

The latest cause essentially heat. An higher efficiency means energy savings, lower heating, longer life of insulating materials. The smaller a motor is, the more the presence of a double lip oil seal as the ones used on the drive end of delphi flanged motors (B5 or B14) may affect, following the friction generated, performance. The motors B3 up to size 132, however, have V-rings with an almost non existent level of friction. For simplicity, the following performance tables indicate the levels of absorption and performance measured on B14 motors for size 56 and B3 motors for size 63 and above.

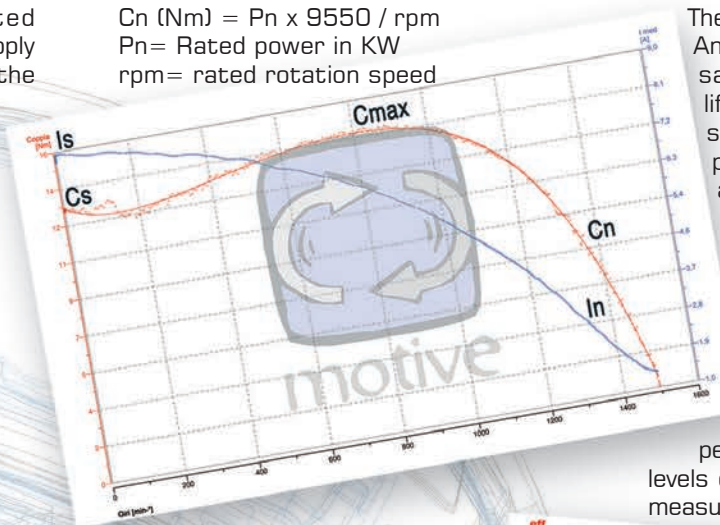

Starting torque (or locked rotor torque): Cs is the torque that the motor can provide with the rotor at a standstill and the rated power supply.

Maximum torque: Cmax is the maximum torque developed by the motor at the rated power supply, at a certain speed. It represents also the value of the resistant torque after which the motor stops. In the following performance charts, it is indicated the relation between maximum torque and rated torque and maximum torque

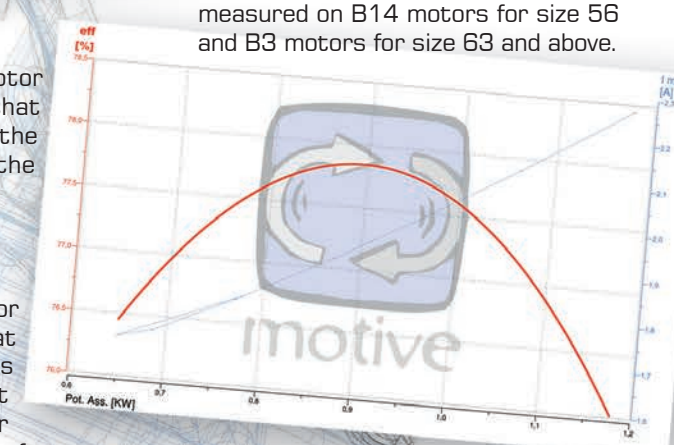

Power factor or cosφ:
it represents the coseno of the voltage and current gap angle.

DATI TECHNICAL DATA

temperature rise ΔT :
The temperature rise " ΔT " is the change in temperature of the entire winding of the motor, including the wire placed deep inside the stator slots, when it is being operated at full load.

For example: if a motor is located in a room with a temperature of 40°C, and then is started and operated continuously at the rated power, the winding temperature would rise from 40°C to a higher temperature. The difference between its starting temperature and the final inner elevated temperature, is the ΔT . Motive Delphi series motors are designed to offer a very low heating level, class B or lower, while their insulation system is at least class F (upgraded to class H for the Delfire series).

Class	amb T (°C)	ΔT (°C)	hot spot allowance (°C)	Tmax (°C)
A	40	60	5	105
E	40	75	5	120
B	40	80	5	130
F	40	105	10	155
H	40	125	15	180

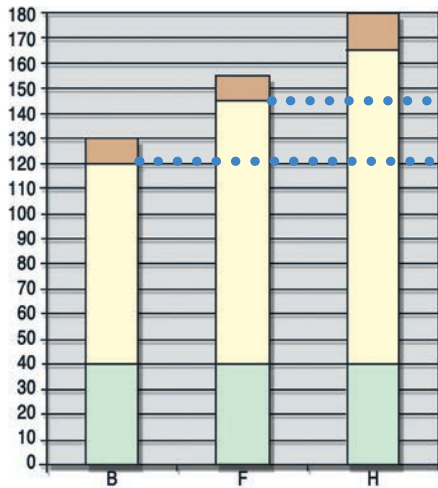

example of overload capability (=life bonus) of an F class motor, with B class temperature rise

hot spot allowance
 ΔT
T. amb.

This extra margin gives the motor a "life bonus". As a rule of thumb, insulation life will be doubled for each 10 degrees of unused insulation temperature capability. The most common method of measuring the temperature rise of a motor is based on the differences between the cold and hot ohmic resistance of the winding.

Noise:
The noise is expressed in dB(A). The measures must be taken in accordance with the standard ISO 1680-2, in order to find the Sound Power level LwA measured at 1m of distance from the perimeter of the machine. EN 60034-9 standard describes the acoustic Power limits to be respected, indicating the maximum sound power level LwA. The noise values indicated in the performance charts that follow are referred to a no-load motor working, supplied at 50Hz and with a tolerance of +3 dB(A).

The moment of inertia can be calculated in this way:
 $J = (1/2) \times M \times (R^2)$
Where M [Kg] is the rotation mass, while R [m] is the ray of the volume at cylindrical symmetry.

TOLERANCES

The data of each motor are specified in this catalogue like requested by the norm IEC 34-1. This describes, in particular, the following tolerances:

Efficiency (Output Power input Power)	-15% di (1 - η)
Power factor	1/6 di (1 - $\cos\phi$) min. 0.02 max 0.07
Locked rotor torque	-15% of the guaranteed torque +25% of the guaranteed torque
Maximum torque	-10% -of the guaranteed torque, if torque is not less than 1,5- 1,6 the rated torque
Noise	+3dB
ΔT	+10°C

The formula is:

$\Delta T [^{\circ}C] = (R2-R1)/R1 * (234,5+T1) - (T2-T1)$ Where:
R1 = Cold winding resistance in Ohms (just before that the test begins)
R2= Hot winding resistance in Ohms (when the motor has reached its thermal equilibrium)
T1= ambient temperature in °C when test begins
T2= ambient temperature in °C when test is stopped

To change ΔT from Centigrade to Fahrenheit:
 $^{\circ}C (\Delta T) \times 1,8$

Note: The motor surface temperature will never exceed the internal temperature of the motor, and will depend upon the design and cooling arrangements.

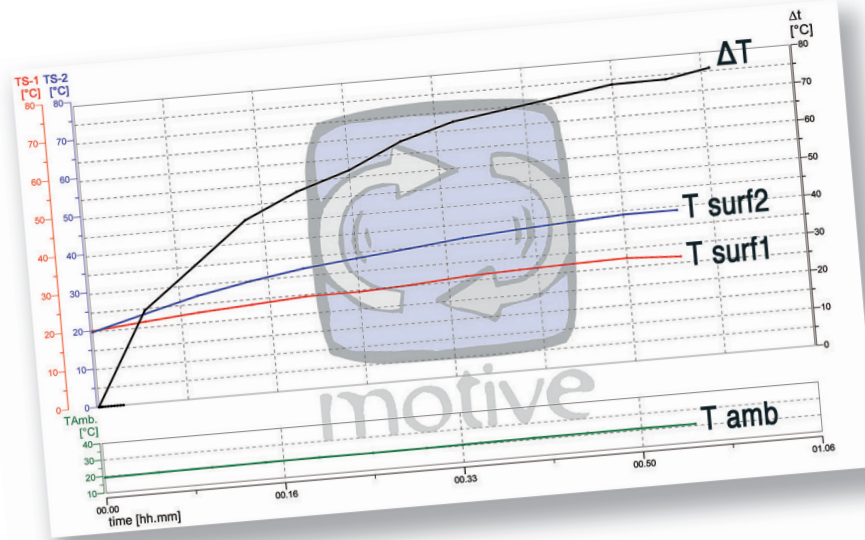

The test reports on which the following tables are based can be downloaded from <https://www.motive.it/en/rapporti.php>

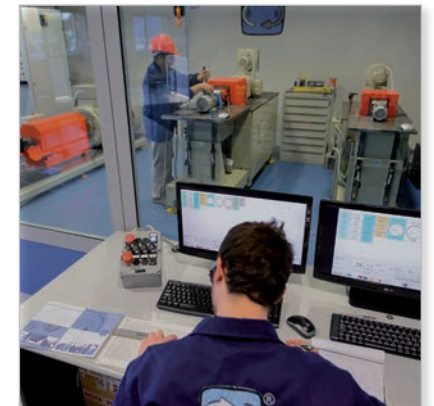



Motive lowest efficiency is IE2 "high efficiency"
[when IE2≥0,75kW, according to European Regulations, the motor is not for direct on line operation]

KW	Hp	Type	rpm	In [A]	Is [A]	Is / In	Cn [Nm]	Cs [Nm]	Cs / Cn	Cmax [Nm]	Cmax / Cn	η %				min IE2	min IE3	Pwr. Fact. Cosφ			ΔT [°C]	LwA [dB]	J Kgm²	Kg
												100%	IE...	75%	50%			100%	75%	50%				
0,13	0,18	56B-2	2635	0,36	1,06	3,0	0,47	0,95	2,0	0,94	2,0	65,5	IE3	65,3	63,0	53,6	60,8	0,806	0,639	0,500	23	60	0,00023	3,5
0,18	0,25	63A-2	2875	0,59	2,68	5,9	0,60	2,25	3,8	2,19	3,7	71,0	IE3	65,6	57,7	60,4	65,9	0,642	0,526	0,417	37	61	0,00031	4,3
0,25	0,35	63B-2	2823	0,65	2,82	4,5	0,85	2,06	2,4	2,32	2,7	76,4	IE3	75,4	71,4	64,8	69,7	0,729	0,599	0,469	49	61	0,00060	4,4
0,37	0,5	63C-2	2791	0,93	4,13	4,5	1,27	3,60	2,8	3,67	2,9	76,4	IE3	76,3	72,8	69,5	73,8	0,755	0,650	0,505	51	61	0,00075	4,9
0,37	0,5	71A-2	2820	0,94	4,33	4,6	1,25	2,90	2,3	3,53	2,8	74,0	IE3	73,7	69,1	69,5	73,8	0,770	0,670	0,525	43	64	0,00080	5,7
0,75	1	71C-2	2834	1,60	9,21	5,4	2,53	7,63	3,0	7,78	3,0	81,6	IE3	82,5	80,8	77,4	80,7	0,811	0,740	0,604	57	64	0,00279	8,0
0,75	1	80A-2	2890	1,76	10,64	6,1	2,48	5,90	2,4	7,80	3,1	80,0	IE2	79,0	75,2	77,4	80,7	0,770	0,700	0,559	42	67	0,00132	9,1
1,1	1,5	80B-2	2868	2,53	14,07	6,0	3,66	9,40	3,0	10,95	3,0	80,7	IE2	80,7	77,8	79,8	-	0,772	0,671	0,521	72	67	0,00124	10,4
1,5	2	80C-2	2849	3,30	19,15	6,0	4,96	14,69	3,0	14,60	3,0	82,0	IE2	83,1	81,7	81,3	-	0,784	0,705	0,568	75	67	0,00144	11,8
1,5	2	90S-2	2864	3,17	18,62	5,9	5,00	12,30	2,5	15,32	3,1	82,1	IE2	82,1	79,7	81,3	-	0,833	0,760	0,640	62	72	0,00319	13,2
2,2	3	90L-2	2859	4,51	28,31	6,3	7,35	22,30	3,0	23,16	3,2	83,6	IE2	85,0	83,9	83,2	-	0,843	0,780	0,660	70	72	0,00605	15,8
3	4	100L-2	2875	5,87	36,50	6,2	10,04	22,47	2,2	28,34	2,8	84,8	IE2	86,9	86,2	84,6	-	0,883	0,833	0,717	77	76	0,00518	25,0
4	5,5	100LB-2	2885	7,73	54,36	7,1	13,32	35,47	2,6	42,82	3,2	85,9	IE2	87,0	86,9	85,8	-	0,873	0,822	0,721	83	76	0,02053	27,0
4	5,5	112M-2	2887	7,49	46,28	6,2	13,23	28,70	2,2	41,00	3,1	85,8	IE2	86,8	85,9	85,8	-	0,899	0,860	0,768	72	77	0,01386	28,0
5,5	7,5	112MB-2	2893	9,98	72,39	7,4	18,33	49,04	2,7	59,70	3,3	87,2	IE2	88,2	87,7	87,0	-	0,922	0,892	0,816	87	77	0,03740	34,0
5,5	7,5	132SA-2	2915	10,18	81,38	8,0	18,01	58,62	2,6	58,62	3,5	87,2	IE2	87,4	84,7	87,0	-	0,876	0,834	0,751	65	80	0,02750	40,0
7,5	10	132SB-2	2910	13,65	95,55	7,1	24,71	54,25	2,2	77,52	3,1	88,5	IE2	89,5	88,5	88,1	-	0,903	0,872	0,796	77	80	0,03300	45,5
9,2	12,5	132MA-2	2911	16,62	131,15	8,1	30,18	85,86	2,8	109,89	3,6	89,5	IE2	90,1	89,1	89,4	-	0,895	0,860	0,784	82	81	0,03740	53,0
11	15	132MB-2	2913	19,03	152,23	8,0	36,09	91,02	2,5	126,03	3,5	90,4	IE2	90,9	90,2	89,4	-	0,918	0,895	0,837	57	81	0,03960	55,0
11	15	160MA-2	2932	19,82	127,63	6,4	35,83	78,40	2,2	56,10	1,6	89,5	IE2	89,3	87,3	89,4	-	0,895	0,870	0,810	56	86	0,04147	110,0
15	20	160MB-2	2945	27,18	168,91	6,3	48,48	102,21	2,1	134,30	2,8	90,7	IE2	91,0	90,0	90,3	-	0,867	0,844	0,774	79	86	0,41063	120,0
18,5	25	160L-2	2930	32,50	229,12	7,1	60,30	155,14	2,6	93,96	3,2	91,3	IE2	91,5	90,6	90,9	-	0,895	0,876	0,816	72	86	0,06050	135,0
22	30	180M-2	2959	39,26	278,51	7,1	71,00	174,50	2,5	220,80	3,1	91,4	IE2	90,8	88,4	91,3	-	0,885	0,860	0,804	52	89	0,08250	165,0
30	40	200LA-2	2969	51,91	355,30	6,8	96,80	194,54	2,0	322,98	3,3	92,5	IE2	92,3	90,7	92,0	-	0,902	0,879	0,824	60	92	0,13640	217,0
37	50	200LB-2	2949	64,06	391,35	6,1	119,82	260,00	2,2	330,00	2,8	92,5	IE2	92,3	89,0	92,5	-	0,901	0,888	0,841	35	92	0,15290	243,0
45	60	225M-2	2963	78,28	472,34	6,0	145,04	320,00	2,2	380,00	2,6	93,5	IE2	93,3	90,2	92,9	-	0,887	0,865	0,804	69	92	0,25630	320,0
55	75	250M-2	2981	95,63	545,37	5,7	176,20	352,40	2,0	475,74	2,7	93,5	IE2	91,6	87,5	93,2	-	0,888	0,870	0,823	45	93	0,34320	390,0
75	100	280S-2	2970	127,69	614,63	4,8	241,16	409,97	1,7	482,32	2,0	94,3	IE2	92,4	88,3	93,8	-	0,899	0,895	0,874	55	94	0,63690	540,0
90	125	280M-2	2974	153,09	796,95	5,2	289,00	520,21	1,8	693,61	2,4	94,2	IE2	94,1	92,1	94,1	-	0,901	0,895	0,858	60	94	0,74250	590,0
110	150	315S-2	2980	185,05	1313,83	7,1	352,52	634,53	1,8	775,54	2,2	94,4	IE2	93,8	92,0	94,3	-	0,909	0,903	0,840	68	96	1,29800	880,0
132	180	315MA-2	2980	218,75	1553,14	7,1	423,02	761,44	1,8	930,64	2,2	95,0	IE2	94,4	93,0	94,6	-	0,917	0,912	0,903	66	96	2,00200	1000,0
160	215	315LA-2	2980	262,63	1864,69	7,1	512,75	922,95	1,8	1128,05	2,2	95,0	IE2	94,4	92,9	94,8	-	0,926	0,913	0,858	69	99	2,28800	1055,0
200	270	315LB-2	2980	334,84	2377,36	7,1	640,94	1153,69	1,8	1410,07	2,2	95,6	IE2	95,1	93,9	95,0	-	0,902	0,889	0,845	62	99	2,61800	1110,0
250	335	355M-2	2985	410,72	2916,11	7,1	799,83	1279,73	1,6	1759,63	2,2	95,6	IE2	95,1	93,8	95,0	-	0,919	0,908	0,878	65	103	3,30000	1900,0
315	423	355L-2	2985	524,82	3726,23	7,1	1007,79	1612,46	1,6	2217,14	2,2	95,2	IE2	94,9	94,0	95,0	-	0,910	0,890	0,870	69	103	3,85000	2300,0



4 Poles

Motive lowest efficiency is IE2 "high efficiency"
 [when IE2≥0,75kW, according to European Regulations, the motor is not for direct on line operation]

data at 400V 50Hz

KW	Hp	Type	rpm	In [A]	Is [A]	Is / In	Cn [Nm]	Cs [Nm]	Cs / Cn	Cmax [Nm]	Cmax / Cn	η %				min IE2	min IE3	Pwr. Fact. Cosφ			ΔT [°C]	LwA [dB]	J Kg·m²	Kg
												100%	IE...	75%	50%			100%	75%	50%				
0,09	0,12	56B-4	1346	0,33	0,97	2,9	0,64	1,80	2,8	1,80	2,8	60,7	IE2	58,0	43,0	-	-	0,6	0,540	0,360	25	52	0,00040	3,7
0,13	0,18	63A-4	1379	0,40	1,30	1,0	0,91	1,96	2,1	2,17	2,3	67,0	IE2	65,6	63,0	64,7	-	0,7	0,578	0,479	41	52	0,00039	4,3
0,18	0,25	63B-4	1391	0,55	1,91	3,5	1,26	3,19	2,5	3,23	2,5	70,1	IE3	68,9	63,4	64,7	69,9	0,7	0,580	0,452	42	52	0,00043	4,8
0,25	0,35	63C-4	1380	0,72	2,41	3,3	1,73	4,10	2,4	4,00	2,3	71,0	IE2	71,3	67,6	68,5	-	0,7	0,601	0,468	51	52	0,00055	5,4
0,25	0,35	71A-4	1400	0,69	2,90	4,2	1,71	4,30	2,5	4,57	2,7	72,7	IE2	72,0	68,0	68,5	-	0,7	0,615	0,500	41	55	0,00080	5,8
0,37	0,5	71B-4	1397	1,11	3,72	3,7	2,59	6,00	2,3	6,10	2,4	73,2	IE2	72,0	61,2	72,7	-	0,7	0,630	0,412	61	55	0,00130	6,3
0,55	0,75	71C-4	1386	1,41	6,19	4,4	3,79	9,13	2,4	10,00	2,6	77,2	IE2	78,5	76,9	77,1	-	0,7	0,620	0,506	56	55	0,00170	7,6
0,55	0,75	80A-4	1431	1,60	7,24	4,5	3,77	9,83	2,5	10,88	2,8	77,1	IE2	74,0	68,1	77,1	-	0,7	0,532	0,410	54	58	0,00180	10,0
0,75	1	80B-4	1440	2,47	12,26	6,4	5,37	17,10	3,4	17,51	3,5	80,3	IE2	79,7	77,5	79,6	-	0,6	0,533	0,435	43	56	0,00233	10,6
1,1	1,5	80C-4	1411	2,81	11,84	4,2	7,63	17,86	2,3	18,57	2,4	81,7	IE2	83,1	81,3	81,4	-	0,7	0,617	0,474	67	58	0,00232	11,8
1,1	1,5	90S-4	1409	2,85	11,44	4,0	7,62	17,07	2,2	17,27	2,3	81,4	IE2	82,4	79,0	81,4	-	0,7	0,612	0,446	21	61	0,00253	12,6
1,5	2	90L-4	1413	3,54	18,44	5,2	10,14	27,60	2,7	31,05	3,1	82,9	IE2	84,0	82,8	82,8	-	0,7	0,644	0,531	59	61	0,00297	15,7
1,9	2,6	90LB-4	1415	4,47	23,24	5,2	12,82	24,61	1,9	26,50	2,1	84,3	IE2	84,6	82,0	84,3	-	0,7	0,630	0,488	55	61	0,00495	16,0
2,2	3	100LA-4	1435	4,80	25,82	5,4	14,64	33,20	2,3	41,87	2,9	84,4	IE2	84,5	82,1	84,3	-	0,8	0,668	0,546	68	64	0,00594	19,7
3	4	100LB-4	1407	6,39	27,93	4,4	20,36	41,20	2,0	30,12	1,5	85,5	IE2	87,9	87,1	85,5	-	0,8	0,700	0,550	65	64	0,00744	24,6
4	5,5	112M-4	1425	8,01	40,17	5,3	27,62	51,04	1,8	65,40	2,4	86,6	IE2	88,2	88,0	86,6	-	0,9	0,800	0,675	84	65	0,01437	28,0
5	6,8	112MB-4	1446	10,45	64,45	6,0	33,19	78,88	2,2	102,58	2,8	88,1	IE2	88,3	87,0	87,7	-	0,8	0,700	0,573	74	65	0,19660	35,0
5,5	7,5	132S-4	1446	10,91	63,83	6,0	36,89	76,07	2,1	98,46	2,7	87,8	IE2	89,5	88,5	87,7	-	0,8	0,780	0,660	70	71	0,03554	39,0
7,5	10	132M-4	1446	14,36	89,86	6,3	49,90	106,64	2,1	135,21	2,7	88,8	IE2	89,7	70,0	88,7	-	0,9	0,810	0,716	79	71	0,04670	47,0
9,2	12,5	132MB-4	1426	16,71	95,09	5,7	61,61	123,30	2,0	97,88	1,6	89,9	IE2	92,2	92,6	89,8	-	0,9	0,850	0,784	96	72	0,03444	55,0
11	15	132MC-4	1461	21,96	170,43	7,8	71,90	196,40	2,7	186,95	2,6	89,8	IE2	89,8	87,8	89,8	-	0,8	0,770	0,610	80	73	0,04444	57,0
11	15	160M-4	1460	21,67	134,07	6,2	71,95	153,40	2,1	208,66	2,9	89,8	IE2	89,4	87,6	89,8	-	0,8	0,776	0,654	70	75	0,06777	118,0
15	20	160L-4	1456	28,12	178,96	6,4	98,39	197,10	2,0	245,96	2,5	90,8	IE2	91,7	90,6	90,6	-	0,8	0,810	0,717	72	75	0,10199	132,0
18,5	25	180M-4	1476	34,45	215,02	6,2	119,70	220,90	1,8	334,30	2,8	91,2	IE2	91,1	89,9	91,2	-	0,9	0,810	0,723	51	76	0,15443	164,0
22	30	180L-4	1470	39,57	202,00	5,1	142,93	255,00	1,8	357,31	2,5	91,6	IE2	91,6	90,8	91,6	-	0,9	0,847	0,775	75	76	0,17554	182,0
37	50	225S-4	1484	66,57	347,40	5,3	240,30	399,80	1,7	575,00	2,4	92,9	IE2	93,3	92,4	92,7	-	0,9	0,843	0,775	68	81	0,58630	258,0
45	60	225M-4	1480	79,02	437,00	5,5	290,37	570,00	2,0	710,00	2,4	93,3	IE2	93,3	92,1	93,1	-	0,9	0,863	0,799	70	81	0,52106	290,0
55	75	250M-4	1480	97,61	585,64	6,0	354,90	674,31	1,9	816,27	2,3	93,7	IE2	96,1	93,0	93,5	-	0,9	0,841	0,780	75	83	0,73326	388,0
75	100	280S-4	1484	129,70	648,48	5,0	482,65	854,00	1,8	915,00	1,9	94,1	IE2	94,2	92,2	94,0	-	0,9	0,860	0,840	68	80	1,43000	510,0
90	120	280M-4	1485	152,96	747,77	4,9	578,79	1041,82	1,8	1150,00	2,0	94,7	IE2	94,7	94,7	94,2	-	0,9	0,889	0,854	54	86	1,63900	606,0
110	150	315S-4	1489	189,80	1138,79	6,0	705,51	1481,56	2,1	1834,32	2,6	95,1	IE2	94,6	92,6	94,5	-	0,9	0,860	0,803	71	93	3,44300	910,0
132	180	315M-4	1485	224,09	1174,96	5,2	848,89	1612,89	1,9	2207,11	2,6	95,2	IE2	95,3	94,7	94,7	-	0,9	0,875	0,831	55	93	4,01500	1000,0
160	220	315LA-4	1485	276,24	1906,08	6,9	1028,96	2160,81	2,1	2263,70	2,2	95,0	IE2	94,5	94,0	94,9	-	0,9	0,850	0,800	61	97	4,52320	1055,0
200	270	315LB-4	1481	339,92	2345,45	6,9	1289,67	2708,31	2,1	2837,27	2,2	95,1	IE2	94,7	93,8	95,1	-	0,9	0,885	0,844	68	97	5,29100	1128,0
250	335	355M-4	1483	420,03	2898,23	6,9	1609,91	3380,82	2,1	3541,81	2,2	95,6	IE2	95,4	94,7	95,1	-	0,9	0,897	0,874	67	101	7,18300	1700,0
315	423	355L-4	1490	524,91	3621,87	6,9	2018,96	4239,82	2,1	4441,71	2,2	95,7	IE2	95,5	94,7	95,1	-	0,9	0,883	0,818	70	101	9,06400	1900,0

KW	Hp	Type	rpm	In [A]	Is [A]	Is / In	Cn [Nm]	Cs [Nm]	Cs / Cn	Cmax [Nm]	Cmax / Cn	η %				min IE2	Pwr. Fact. Cosφ			ΔT [°C]	LwA [dB]	J Kgm²	Kg
												100%	IE...	75%	50%		100%	75%	50%				
0,18	0,25	71A-6	921	0,66	1,93	2,9	1,87	4,20	2,3	4,30	2,3	62,7	IE2	61,1	53,7	56,6	0,631	0,540	0,418	41,4	51	0,00110	6,7
0,25	0,35	71B-6	910	0,87	2,62	3,0	2,62	6,00	2,3	6,00	2,3	64,0	IE2	62,5	57,1	61,6	0,650	0,550	0,426	54,3	51	0,00140	7,1
0,37	0,5	80A-6	921	1,12	3,63	3,2	3,81	7,62	2,0	7,57	2,0	68,9	IE2	68,6	62,5	67,6	0,689	0,609	0,450	52	53	0,00160	8,8
0,55	0,75	80B-6	907	1,48	4,77	3,2	5,73	10,34	1,8	11,18	2,0	73,1	IE2	74,5	72,1	73,1	0,732	0,660	0,515	63	53	0,00190	10,6
0,75	1	90S-6	915	2,01	5,98	3,0	7,83	13,00	1,7	9,97	1,3	76,0	IE2	77,9	75,2	75,9	0,710	0,610	0,480	69,1	57	0,00319	12,8
1,1	1,5	90L-6	915	2,74	9,93	3,6	11,48	22,10	1,9	16,57	1,4	78,3	IE2	80,2	79,3	78,1	0,740	0,650	0,560	66,7	57	0,00385	15,8
1,5	2	100L-6	944	3,91	16,15	4,1	15,17	29,39	1,9	35,09	2,3	79,9	IE2	80,3	77,6	79,8	0,693	0,609	0,477	70,8	58	0,00759	23,0
2,2	3	112M-6	951	5,45	25,84	4,7	22,09	45,40	2,1	57,79	2,6	81,9	IE2	82,7	80,4	81,8	0,712	0,610	0,475	73,7	61	0,01540	25,0
3	4	132S-6	969	6,95	38,23	5,5	29,57	62,40	2,1	81,20	2,7	84,5	IE2	84,6	82,1	83,3	0,737	0,710	0,536	62,8	64	0,03146	28,0
4	5,5	132MA-6	969	8,85	56,55	6,4	39,42	89,90	2,3	121,80	3,1	84,7	IE2	84,5	82,0	84,6	0,770	0,690	0,566	76,2	64	0,03927	45,0
5,5	7,5	132MB-6	966	12,38	65,09	5,3	54,37	103,20	1,9	95,28	1,8	87,0	IE2	87,5	87,0	86,0	0,737	0,653	0,545	64	64	0,04961	55,0
7,5	10	160M-6	978	16,97	88,24	5,2	73,24	109,85	1,5	146,47	2,0	88,6	IE2	89,2	88,5	87,2	0,720	0,670	0,600	56,4	71	0,08910	118,0
11	15	160L-6	970	23,37	106,35	4,6	108,30	173,28	1,6	184,11	1,7	89,5	IE2	90,5	89,9	88,7	0,759	0,700	0,582	79,4	71	0,12760	125,0
15	20	180L-6	984	29,79	140,65	4,7	145,58	232,93	1,6	334,83	2,3	89,8	IE2	89,4	88,0	89,7	0,809	0,750	0,657	63,1	73	0,22770	160,0
18,5	25	200LA-6	970	35,28	183,46	5,2	182,14	327,85	1,8	454,99	2,5	91,0	IE2	90,8	89,7	90,4	0,832	0,781	0,685	59,3	76	0,34650	217,0
22	30	200LB-6	982	42,61	215,40	5,1	213,95	385,11	1,8	534,88	2,5	91,1	IE2	91,0	89,3	90,9	0,818	0,763	0,668	79,9	76	0,39600	244,0
30	40	225M-6	980	55,62	236,55	4,3	292,35	503,00	1,7	518,00	1,8	91,8	IE2	91,6	92,0	91,7	0,848	0,828	0,759	59,8	76	0,60170	295,0
37	50	250M-6	983	68,00	297,27	4,4	359,46	611,08	1,7	718,92	2,0	92,6	IE2	92,3	92,4	92,2	0,848	0,828	0,759	56	78	0,92730	365,0
45	60	280S-6	982	78,93	360,33	4,6	437,63	700,20	1,6	919,02	2,1	93,2	IE2	93,6	92,2	92,7	0,883	0,865	0,813	42,4	80	1,52900	500,0
55	75	280M-6	985	96,24	459,99	4,8	533,25	853,20	1,6	1119,82	2,1	93,1	IE2	93,6	93,2	93,1	0,886	0,873	0,822	71,6	80	1,81500	545,0
75	100	315S-6	986	132,96	534,60	4,0	726,42	1162,27	1,6	1307,56	1,8	94,5	IE2	95,1	94,4	93,7	0,862	0,860	0,820	69,4	85	4,52100	810,0
90	125	315MA-6	985	159,67	1069,81	6,7	872,59	1745,18	2,0	1745,18	2,0	94,6	IE2	94,5	93,6	94,0	0,860	0,831	0,766	69	85	5,25800	900,0
110	150	315LA-6	985	195,78	1311,71	6,7	1066,50	2132,99	2,0	2132,99	2,0	94,3	IE2	93,9	93,7	94,3	0,860	0,840	0,820	70	85	5,99500	1010,0
132	180	315LB-6	985	233,94	1567,40	6,7	1279,80	2559,59	2,0	2559,59	2,0	94,7	IE2	94,2	93,7	94,6	0,860	0,840	0,810	68	85	6,73200	1140,0
160	220	355MA-6	990	279,71	1874,08	6,7	1543,43	2932,53	1,9	3086,87	2,0	94,9	IE2	94,2	93,3	94,8	0,870	0,870	0,850	67	92	10,45000	1550,0
200	270	355MB-6	990	341,43	2287,55	6,7	1929,29	3665,66	1,9	3858,59	2,0	95,0	IE2	94,5	94,0	95,0	0,890	0,870	0,850	65	92	11,44000	1600,0
250	335	355L-6	990	431,63	2891,93	6,7	2411,62	4582,07	1,9	4823,23	2,0	95,0	IE2	95,0	94,0	95,0	0,880	0,860	0,840	65	92	13,64000	1700,0



KW	Hp	Type	rpm	In [A]	Is [A]	Is / In	Cn [Nm]	Cs [Nm]	Cs / Cn	Cmax [Nm]	Cmax / Cn	η %				min IE2	min IE3	Pwr. Fact. Cosφ			ΔT [°C]	LwA [dB]	J Kgm²	Kg
												100%	IE...	75%	50%			100%	75%	50%				
0,13	0,18	71B-8	651	0,71	1,48	2,1	1,91	3,80	2,0	3,93	2,1	48,2	IE2	44,9	39,0	39,8	50,7	0,550	0,460	0,390	76	52	0,00080	6,8
0,18	0,25	80A-8	694	0,83	2,01	2,4	2,48	4,70	1,9	5,50	2,2	56,1	IE2	51,0	44,7	45,9	58,7	0,560	0,460	0,392	54	52	0,00180	10,0
0,25	0,35	80B-8	691	1,10	2,62	2,4	3,46	6,90	2,1	7,06	2,2	61,0	IE2	58,2	52,2	50,6	64,1	0,540	0,450	0,373	56	52	0,00190	10,8
0,37	0,5	90S-8	670	1,41	5,65	4,0	5,27	10,55	2,0	10,55	2,0	62,0	IE2	61,0	54,0	56,1	69,3	0,610	0,550	0,350	36	54	0,00210	13,0
0,55	0,75	90L-8	701	2,04	6,25	3,1	7,49	15,50	2,1	18,00	2,4	68,3	IE2	66,0	58,1	61,7	73,0	0,570	0,490	0,366	22	54	0,00240	14,0
0,75	1	100LA-8	712	2,24	8,66	3,86	10,06	21,70	2,16	25,09	2,49	75,9	IE3	75,1	70,3	66,2	75,0	0,636	0,550	0,426	47	57	0,00900	23,0
1,1	1,5	100LB-8	702	3,38	12,14	3,6	14,96	31,30	2,1	35,91	2,4	73,9	IE2	73,4	68,5	70,8	77,7	0,635	0,524	0,397	65	57	0,01000	25,0
1,5	2	112M-8	711	4,21	16,94	4,0	20,15	43,80	2,2	50,70	2,5	79,2	IE2	79,8	79,0	74,1	79,7	0,650	0,550	0,500	48	61	0,02450	28,0
2,2	3	132S-8	710	5,54	33,23	6,0	29,59	53,26	1,8	59,18	2,0	81,9	IE3	82,2	80,0	77,6	81,9	0,700	0,660	0,481	57	64	0,03140	45,0
3	4	132M-8	716	7,25	31,48	4,3	40,01	71,90	1,8	93,01	2,3	83,0	IE2	83,9	82,2	80,0	83,5	0,720	0,650	0,494	63	64	0,03950	55,0
4	5,5	160MA-8	722	9,34	44,12	4,7	52,95	92,38	1,7	125,82	2,4	84,8	IE3	85,1	83,0	81,9	84,8	0,730	0,671	0,531	67	68	0,07530	110,0
5,5	7,5	160MB-8	726	12,39	54,99	4,4	72,35	11,72	1,5	162,63	2,2	84,5	IE2	83,3	79,2	83,8	86,2	0,758	0,698	0,580	46	68	0,09310	120,0
7,5	10	160L-8	727	16,23	78,06	4,8	95,40	178,55	1,9	233,11	2,4	85,5	IE2	84,8	82,3	85,3	87,3	0,772	0,723	0,609	51	68	0,12600	135,0
11	15	180L-8	730	23,48	129,17	5,5	143,90	287,81	2,0	287,81	2,0	87,8	IE2	87,9	87,5	86,9	88,6	0,770	0,700	0,650	51	70	0,20300	160,0
15	20	200L-8	730	31,03	204,78	6,6	196,23	392,47	2,0	392,47	2,0	89,5	IE2	89,4	87,8	88,0	89,6	0,780	0,709	0,580	69	73	0,33900	235,0
18,5	25	225S-8	730	38,48	253,99	6,6	242,02	459,84	1,9	484,04	2,0	91,3	IE3	91,5	90,5	88,6	90,1	0,760	0,720	0,680	57	73	0,49100	242,0
22	30	225M-8	730	44,84	295,97	6,6	287,81	546,84	1,9	575,62	2,0	91,3	IE3	91,6	90,6	89,1	90,6	0,776	0,727	0,608	69	73	0,54700	285,0
30	40	250M-8	730	59,32	391,51	6,6	392,47	745,68	1,9	784,93	2,0	92,4	IE3	92,3	91,0	89,8	91,3	0,790	0,760	0,720	65	75	0,84300	390,0
37	50	280S-8	740	71,62	312,00	4,3	485,60	752,16	1,5	987,02	2,0	92,5	IE3	93,0	92,2	90,3	91,8	0,819	0,778	0,683	67	76	8,78078	500,0
45	60	280M-8	740	89,93	416,22	4,6	580,74	900,10	1,6	1316,04	2,3	92,3	IE3	92,2	91,7	90,7	92,2	0,819	0,778	0,679	57	76	1,65000	580,0
55	75	315S-8	740	104,10	687,05	6,6	709,80	1277,64	1,8	1419,59	2,0	93,0	IE3	93,0	92,0	91,0	92,5	0,820	0,760	0,650	66	82	4,79000	790,0
75	100	315MA-8	740	142,91	943,23	6,6	967,91	1742,23	1,8	1935,81	2,0	93,4	IE3	92,8	91,1	91,6	93,1	0,811	0,744	0,614	67	82	5,58000	970,0
90	125	315LA-8	740	168,57	1112,56	6,6	1161,49	2090,68	1,8	2322,97	2,0	93,8	IE3	93,3	91,6	91,9	93,4	0,822	0,769	0,641	67	82	6,37000	1055,0
110	150	315LB-8	740	205,82	1317,24	6,4	1419,59	2555,27	1,8	2839,19	2,0	94,4	IE3	94,1	92,7	92,3	93,7	0,817	0,754	0,629	65	82	7,23000	1118,0
132	180	355MA-8	740	247,97	1587,01	6,4	1703,51	3066,32	1,8	3407,03	2,0	93,7	IE2	93,7	93,1	92,6	94,0	0,820	0,820	0,760	64	82	7,60000	2000,0
160	220	355MB-8	740	298,97	1913,44	6,4	2064,86	3716,76	1,8	4129,73	2,0	94,2	IE2	94,2	93,5	93,0	94,3	0,820	0,820	0,760	61	82	7,70000	2150,0
200	270	355L-8	740	368,04	2355,48	6,4	2581,08	4645,95	1,8	5162,16	2,0	94,5	IE2	94,5	93,0	93,5	94,6	0,830	0,830	0,790	62	82	8,20000	2250,0
250	335	355LB-8	740	467,15	2989,75	6,4	3226,35	5807,43	1,8	6452,70	2,0	94,2	IE2	94,2	93,1	93,5	94,6	0,820	0,820	0,780	65	82	8,30000	2350,0

To get the data double polarity and delfire motors performance data, ask to our commercial office.



IE3, premium efficiency class IEC 60034-30-1

data at 400V 50Hz

KW	Hp	Type	rpm	In (A)	Is (A)	Is ----- In	Cn (Nm)	Cs (Nm)	Cs ----- Cn	Cmax (Nm)	Cmax ----- Cn	η %			min IE3	Pwr. fact. cosφ			ΔT (°C)	LwA (dB)	J Kgm²	Kg	
												100%	IE	75%		50%	100%	75%					50%
0,75	1	80A-2	2892	1,74	11,84	6,8	2,48	8,60	3,5	9,18	3,7	80,9	IE3	79,6	76,4	80,7	0,770	0,700	0,566	35	65	0,00158	17,0
1,1	1,5	80B-2	2885	2,26	16,74	7,4	3,64	10,90	3,0	12,74	3,5	84,5	IE3	84,7	82,8	82,7	0,830	0,770	0,652	41	65	0,00185	18,0
1,5	2	80C-2	2849	3,23	18,72	6,0	5,12	15,18	3,0	15,09	3,0	84,3	IE3	85,5	84,0	84,2	0,802	0,722	0,580	75	67	0,00242	11,8
1,5	2	90S-2	2902	3,26	25,07	7,7	4,93	19,12	3,9	18,74	3,8	85,3	IE3	83,4	81,3	84,2	0,786	0,726	0,582	43	71	0,00383	23,0
2,2	3	90L-2	2918	5,02	38,59	7,7	7,35	30,97	4,2	30,44	4,1	86,2	IE3	87,0	84,9	85,9	0,730	0,675	0,498	48	71	0,00726	26,0
3	4	100L-2	2927	6,27	55,58	9,6	9,83	38,85	5,3	44,65	6,1	87,4	IE3	86,7	82,0	87,1	0,789	0,717	0,574	51	75	0,02053	35,0
4	5,5	112M-2	2936	7,45	70,79	9,5	13,00	47,98	3,6	60,74	4,6	88,6	IE3	88,2	86,2	88,1	0,871	0,817	0,705	49	77	0,03558	43,0
5,5	7,5	132SA-2	2940	10,14	70,59	7,0	17,87	37,70	2,1	35,79	2,0	91,0	IE3	89,7	87,4	89,2	0,860	0,840	0,761	48	78	0,03300	66,0
7,5	10	132SB-2	2925	13,35	95,00	7,1	24,49	53,50	2,2	78,50	3,2	91,6	IE3	92,4	92,9	90,1	0,885	0,850	0,760	60	78	0,03960	73,0
11	15	160MA-2	2966	20,56	171,09	8,7	35,29	102,75	2,9	135,34	3,8	91,4	IE3	90,8	88,5	91,2	0,827	0,783	0,695	43	81	0,25313	120,0
15	20	160MB-2	2945	26,80	166,53	6,3	49,17	103,67	2,1	136,23	2,8	92,0	IE3	92,2	91,3	91,9	0,880	0,856	0,785	79	81	0,41063	132,0
18,5	25	160L-2	2942	32,15	192,92	6,0	60,05	124,31	2,1	179,00	2,1	93,0	IE3	93,7	93,0	92,4	0,893	0,875	0,827	58	81	0,07260	150,0
22	30	180M-2	2950	37,53	304,03	8,1	71,22	163,81	2,3	220,80	3,1	94,0	IE3	93,9	93,0	92,7	0,900	0,880	0,870	41	83	0,09900	205,0
30	40	200LA-2	2969	51,33	351,40	6,8	98,00	196,99	2,0	327,04	3,3	93,6	IE3	93,3	91,8	93,3	0,912	0,889	0,833	60	84	0,16368	250,0
37	50	200LB-2	2960	63,26	474,46	7,5	119,38	274,56	2,3	275,49	2,3	93,8	IE3	93,6	90,2	93,7	0,900	0,887	0,840	69	84	0,18348	270,0
45	60	225M-2	2960	76,69	582,87	7,6	145,19	333,93	2,3	332,80	2,3	94,1	IE3	93,9	90,7	94,0	0,900	0,878	0,816	66	86	0,30756	315,0
55	75	250M-2	2970	94,39	707,92	7,5	176,85	406,76	2,3	406,76	2,3	94,5	IE3	92,6	88,5	94,3	0,890	0,872	0,825	61	89	0,41184	420,0
75	100	280S-2	2986	129,84	884,20	5,9	244,80	536,60	1,8	837,25	2,8	94,7	IE3	94,7	91,1	94,7	0,892	0,863	0,795	53	94	0,63690	540,0
90	125	280M-2	2989	149,07	983,90	6,5	287,90	560,90	1,9	1061,28	3,7	95,0	IE3	94,8	93,9	95,0	0,919	0,901	0,866	59	94	0,74250	590,0

0,13	0,18	63A-4	1391	0,55	1,91	3,5	1,26	3,19	2,5	3,23	2,5	70,1	IE3	68,9	63,4	69,9	0,682	0,580	0,452	39	52	0,00157	4,3
0,75	1	80B-4	1446	2,32	11,86	6,4	5,06	17,68	3,4	18,10	3,5	82,7	IE3	80,8	75,6	82,5	0,572	0,471	0,354	43	56	0,00232	12,0
1,1	1,5	90S-4	1417	2,59	13,69	5,5	7,62	23,49	3,1	23,11	3,1	84,2	IE3	84,6	81,4	84,1	0,743	0,661	0,538	37	61	0,00301	25,0
1,5	2	90L-4	1427	3,59	24,34	6,8	10,03	41,06	4,1	38,49	3,8	85,3	IE3	85,1	83,0	85,3	0,708	0,592	0,483	41	61	0,00356	30,0
2,2	3	100LA-4	1459	5,18	39,50	9,1	14,43	54,26	3,7	63,46	4,3	87,0	IE3	86,4	83,7	86,7	0,708	0,507	0,468	41	64	0,00713	36,0
3	4	100LB-4	1447	6,48	49,52	7,6	19,76	69,03	3,5	77,85	3,9	89,0	IE3	89,4	86,8	87,7	0,745	0,648	0,519	46	64	0,00893	40,0
4	5,5	112M-4	1463	8,71	66,06	8,3	26,31	80,63	3,0	107,23	4,0	89,0	IE3	88,2	85,5	88,1	0,758	0,661	0,522	50	77	0,01588	43,0
5,5	7,5	132S-4	1454	10,64	68,01	6,4	36,12	75,86	2,1	101,15	2,8	89,9	IE3	92,1	92,4	89,6	0,830	0,770	0,675	61	71	0,02853	47,5
7,5	10	132M-4	1460	14,39	94,37	6,6	49,06	91,80	1,9	132,46	2,7	90,5	IE3	90,8	89,9	90,4	0,831	0,790	0,699	46	71	0,03946	81,0
11	15	160M-4	1468	20,76	121,31	5,8	71,56	121,50	1,7	193,21	2,7	91,8	IE3	91,7	90,4	91,4	0,833	0,790	0,675	52	73	0,08133	125,0
15	20	160L-4	1473	27,76	176,76	6,3	97,80	161,57	1,6	272,90	2,8	92,3	IE3	92,4	91,0	92,1	0,847	0,807	0,701	65	75	0,38293	150,0
18,5	25	180M-4	1477	33,53	206,45	6,2	120,94	202,50	1,7	384,23	3,2	92,6	IE3	92,1	90,2	92,6	0,870	0,817	0,724	40	76	0,18531	170,6
22	30	180L-4	1470	39,62	261,96	6,6	142,93	235,19	1,6	401,22	2,8	93,2	IE3	91,7	91,0	93,0	0,860	0,832	0,761	59	76	0,21065	189,3
30	40	200L-4	1480	53,48	385,07	7,2	193,58	425,88	2,2	445,24	2,3	93,6	IE3	93,8	92,8	93,6	0,865	0,818	0,767	59	79	0,34930	254,8
37	50	225S-4	1480	65,37	490,30	7,5	238,75	525,25	2,2	549,13	2,3	93,9	IE3	92,7	92,0	93,9	0,870	0,839	0,776	61	81	0,54128	268,3
45	60	225M-4	1488	79,60	502,60	6,5	291,50	581,37	2,0	859,88	2,9	94,6	IE3	94,5	93,4	94,2	0,865	0,820	0,745	65	81	0,62527	353,0
55	75	250M-4	1480	93,89	713,58	7,6	354,90	780,78	2,2	816,27	2,3	95,0	IE3	94,2	93,5	94,6	0,890	0,862	0,800	75	83	0,87991	450,0
75	100	280S-4	1492	127,74	822,60	6,3	480,40	990,59	2,1	1467,26	3,0	95,0	IE3	95,2	94,0	95,0	0,892	0,870	0,817	61	80	1,43000	510,0
90	120	280M-4	1489	152,80	1012,70	6,6	578,10	1207,78	8,7	1729,93	12,4	95,2	IE3	95,2	94,4	95,2	0,899	0,878	0,817	58	86	1,63900	606,0

0,75	1	90S-6	936	2,14	8,79	4,5	7,74	20,97	1,1	22,24	1,2	79,2	IE3	78,7	74,0	78,9	0,647	0,543	0,427	34	55	0,00300	23,0
1,1	1,5	90L-6	945	3,23	13,96	4,3	11,12	34,15	3,1	34,50	3,1	81,1	IE3	80,2	75,8	81,0	0,603	0,529	0,388	49	55	0,00360	17,8
1,5	2	100L-6	955	4,01	21,54	5,4	14,99	47,49	3,2	47,80	3,2	83,0	IE3	83,9	83,4	82,5	0,652	0,508	0,407	45	60	0,00850	35,0
2,2	3	112M-6	968	5,74	30,33	5,3	21,68	51,38	2,4	65,69	3,0	84,8	IE3	84,4	83,1	84,3	0,654	0,525	0,414	53	62	0,01600	44,0
3	4	132S-6	971	6,99	38,51	5,5	29,51	58,10	2,0	76,71	2,6	87,6	IE3	88,0	86,7	85,6	0,707	0,611	0,511	39	68	0,02930	67,0
4	5,5	132MA-6	974	9,34	58,39	6,3	39,22	90,90	2,3	125,50	3,2	88,2	IE3	88,0	86,1	86,8	0,701	0,610	0,484	51	68	0,03720	75,0
5,5	7,5	132MB-6	972	12,46	72,99	5,9	54,04	124,29	2,3	156,71	2,9	90,0	IE3	90,1	89,2	88,0	0,708	0,606	0,492	63	69	0,04780	86,0
7,5	10	160M-6	970	15,56	104,25	6,7	73,84	155,06	2,1	162,45	2,2	89,2	IE3	89,3	88,4	89,1	0,780	0,668	0,542	56	72	0,11583	125,0
11	15	160L-6	970	22,26	153,57	6,9	108,30	227,43	2,1	238,26	2,2	90,3	IE3	90,4	89,5	90,3	0,790	0,676	0,549	64	72	0,14674	150,0
15	20	180L-6	980	29,28	210,79	7,2	146,17	292,35	2,0	306,96	2,1	91,3	IE3	91,4	90,5	91,2	0,810	0,693	0,563	59	72	0,26186	200,0
18,5	25	200LA-6	980	35,95	258,84	7,2	180,28	378,59	2,1	396,62	2,2	91,7	IE3	91,8	90,9	91,7	0,810	0,693	0,563	64	72	0,39848	240,0
22	30	200LB-6	980	41,96	306,27	7,3	214,39	450,21	2,1	471,65	2,2	92,3	IE3	92,4	91,5	92,2	0,820	0,702	0,570	64	72	0,45540	260,0
30	40	225M-6	980	56,78	403,15	7,1	292,35	584,69	2,0	613,93	2,1	93,0	IE3	93,1	92,2	92,9	0,820	0,702	0,570	65	73	0,69196	300,0
37	50	250M-6	986	64,32	307,90	4,6	364,50	519,02	1,4	809,26	2,2	93,6	IE3	94,1	93,7	93,3	0,906	0,890	0,837	65	75	1,06040	420,0
45	60	280S-6	980	80,52	579,73	7,2	438,52	920,89	2,1	964,74	2,2	93,8	IE3	93,9	93,0	93,7	0,860	0,736	0,598	64	75		



IE4, super premium efficiency class IEC 60034-30-1

data at 400V 50Hz

KW	Hp	Type	rpm	In (A)	Is (A)	Is ----- In	Cn (Nm)	Cs (Nm)	Cs ----- Cn	Cmax (Nm)	Cmax ----- Cn	η %			min IE3	min IE4	Pwr. fact. cosφ			ΔT (°C)	LwA (dB)	J Kgm²	Kg	
												100%	IE	75%			50%	100%	75%					50%
0,55	0,75	71B-2	2890	1,32	9,31	7,2	1,80	7,20	3,9	7,63	4,1	82,0	IE4	81,0	77,2	74,1	81,5	0,722	0,628	0,491	36	64	0,00090	6,9
1,5	2	90S-2	2894	2,90	23,15	8,0	4,97	20,08	4,0	19,73	4,0	87,6	IE4	87,5	85,9	84,2	86,5	0,788	0,708	0,578	43	71	0,00974	23,0
2,2	3	90L-2	2918	4,89	37,57	8,4	7,28	31,30	4,2	30,76	4,1	88,5	IE4	89,3	87,1	84,1	87,2	0,738	0,656	0,504	48	71	0,00283	26,0
3	4	100L-2	2927	6,14	54,40	9,6	10,04	39,69	5,3	45,62	6,1	89,3	IE4	87,6	83,8	87,1	89,1	0,806	0,683	0,587	51	75	0,02053	35,0
4	5,5	112M-2	2936	7,32	69,53	9,5	13,23	48,84	3,6	61,84	4,6	90,2	IE4	89,8	87,7	88,1	90,0	0,887	0,832	0,718	49	77	0,03558	43,0
11	15	160MA-2	2966	20,25	168,51	8,7	35,83	104,33	2,9	137,41	3,8	92,8	IE4	92,2	89,8	91,2	92,6	0,840	0,827	0,706	43	75	0,41063	118,0
75	100	280S-2	2970	125,82	868,14	6,9	241,16	530,56	2,2	554,67	2,3	95,6	IE4	93,7	89,5	94,7	95,6	0,900	0,896	0,875	55	91	0,89362	550,8
90	125	280M-2	2980	150,80	980,00	6,5	288,80	610,00	2,1	665,00	2,3	95,8	IE4	93,8	93,0	95,0	95,8	0,900	0,883	0,843	60	91	0,78438	625,0
110	150	315S-2	2970	183,90	1304,70	7,1	354,10	707,40	2,0	778,20	2,2	96,0	IE4	94,6	93,2	95,2	96,0	0,900	0,883	0,843	60	92	1,55760	968,0
132	180	315MA-2	2970	220,20	1562,40	7,1	424,90	848,90	2,0	933,80	2,2	96,2	IE4	94,8	93,3	95,4	96,2	0,900	0,883	0,843	62	92	2,40240	1100,0
160	215	315LA-2	2970	263,70	1871,10	7,1	514,90	1029,00	2,0	1131,90	2,0	96,3	IE4	94,9	93,4	95,6	96,3	0,910	0,892	0,852	63	92	2,74560	1160,5
200	270	315LB-2	2970	328,90	2334,00	7,1	643,60	1286,20	2,0	1414,80	2,2	96,5	IE4	95,1	93,6	95,8	96,5	0,910	0,892	0,852	63	92	3,14160	1221,0
250	335	355M-2	2980	411,00	2917,00	7,1	801,70	1602,40	2,0	1762,00	2,2	96,5	IE4	95,1	93,6	95,8	96,5	0,910	0,892	0,852	62	100	3,96000	2090,0
315	423	355L-2	2980	517,90	3676,00	7,1	1010,10	2019,00	7,1	1414,80	1,4	96,5	IE4	95,1	93,6	95,8	96,5	0,910	0,892	0,852	67	100	4,62000	2530,0
3	4	100LB-4	1447	6,37	48,62	8,1	20,11	70,16	3,5	79,12	3,9	90,7	IE4	91,1	88,5	87,7	90,4	0,756	0,682	0,527	46	64	0,04199	40,0
4	5,5	112M-4	1460	8,65	61,30	7,8	26,83	85,67	3,2	111,28	4,1	91,3	IE4	91,3	89,4	88,6	91,1	0,747	0,701	0,513	46	77	0,01588	43,0
15	20	160L-4	1473	27,23	173,38	6,3	99,71	164,72	1,6	278,23	2,8	94,1	IE4	94,2	92,8	90,6	93,9	0,864	0,823	0,715	65	75	0,38293	150,0
45	60	225M-4	1488	78,80	497,60	6,5	294,70	587,77	2,0	869,35	2,9	95,6	IE4	95,4	94,3	94,2	95,4	0,874	0,838	0,752	65	81	0,72337	353,0
55	75	250M-4	1485	94,77	554,00	6,1	368,10	587,15	1,6	938,18	2,5	95,8	IE4	95,2	93,8	94,6	95,7	0,902	0,877	0,267	76	83	0,87991	450,0
75	100	280S-4	1492	126,15	812,40	6,3	487,50	1005,22	2,1	1488,93	3,0	96,3	IE4	96,4	95,3	95,0	96,0	0,904	0,880	0,828	61	86	1,97005	605,0
90	120	280M-4	1489	151,19	1002,00	6,6	585,30	1222,82	8,7	1751,47	1,4	96,3	IE4	96,3	95,5	95,2	96,1	0,909	0,888	0,826	58	86	2,31241	700,0
110	150	315S-4	1480	187,50	1292,70	6,9	710,60	1561,60	2,2	1632,50	2,3	96,3	IE4	94,9	93,4	95,4	96,3	0,880	0,865	0,824	62	87	3,69498	925,0
132	180	315M-4	1480	224,70	1459,70	6,5	852,60	1873,90	2,2	1959,00	2,3	96,4	IE4	95,0	93,5	95,6	96,4	0,880	0,863	0,824	66	87	4,20012	1180,0
160	220	315LA-4	1480	271,80	1874,00	6,9	1033,30	2271,00	2,2	2374,00	2,3	96,6	IE4	95,2	93,7	95,8	96,6	0,880	0,863	0,824	60	87	19,02115	1160,5
200	270	315LB-4	1480	339,40	2340,70	6,9	1291,60	2839,20	2,2	2968,20	2,3	96,7	IE4	95,3	93,8	96,0	96,7	0,880	0,863	0,824	67	87	5,17720	1240,8
250	335	355M-4	1490	414,70	2960,90	6,9	1603,50	3525,20	2,2	3685,40	2,3	96,7	IE4	95,3	93,8	96,0	96,7	0,900	0,883	0,843	65	94	8,61960	1870,0
315	423	355L-4	1490	522,60	3604,70	6,9	2020,30	4441,70	2,2	4643,00	2,3	96,7	IE4	95,3	93,8	96,0	96,7	0,900	0,878	0,843	70	94	10,87680	2090,0
355	483	400M-4	1490	595,38	4048,56	6,8	2275,34	3868,07	1,7	5005,74	2,2	96,7	IE4	97,4	96,5	96,0	96,7	0,890	0,880	0,870	70	105	14,88000	2860,0
400	544	400MA-4	1490	670,85	4561,75	6,8	2563,76	4358,39	1,7	5640,27	2,2	96,7	IE4	96,6	96,5	96,0	96,7	0,890	0,880	0,870	70	105	15,19000	2980,0
455	620	400MB-4	1490	763,09	5188,99	6,8	2916,28	4957,67	1,7	6415,81	2,2	96,7	IE4	96,6	96,4	96,0	96,7	0,890	0,880	0,870	70	105	15,75000	3080,0
500	675	400LA-4	1490	838,56	5702,19	6,8	3204,70	5447,99	1,7	7050,34	2,2	96,7	IE4	96,6	96,4	96,0	96,7	0,890	0,880	0,870	70	105	18,57000	3345,0
560	760	400LB-4	1490	939,18	6386,45	6,8	3589,26	6101,74	1,7	7896,38	2,2	96,7	IE4	96,6	96,5	96,0	96,7	0,890	0,880	0,870	70	108	19,84000	3490,0
630	857	400LC-4	1490	1056,58	7184,76	6,8	4037,92	6864,46	1,7	8883,42	2,2	96,7	IE4	96,6	96,5	96,0	96,7	0,890	0,880	0,870	70	108	21,51000	3750,0





IE4, super premium efficiency class IEC 60034-30-1

KW	Hp	Type	rpm	In (A)	Is (A)	Is ----- In	Cn (Nm)	Cs (Nm)	Cs ----- Cn	Cmax (Nm)	Cmax ----- Cn	η %			min IE3	min IE4	Pwr. fact. cosφ			ΔT (°C)	LwA (dB)	J Kgm²	Kg	
												100%	IE	75%			100%	75%	50%					
0,75	1	90S-6	950	1,82	8,11	4,5	7,58	18,21	2,3	19,74	2,5	83,9	IE4	83,9	80,3	78,9	82,7	0,699	0,614	0,478	40	55	0,00466	23,0
1,5	2	100L-6	959	3,68	18,36	5,3	15,37	35,77	2,3	42,49	15,5	86,1	IE4	86,1	83,9	82,5	85,9	0,704	0,595	0,467	49	60	0,01152	35,0
2,2	3	112M-6	968	5,59	29,55	5,3	21,82	51,71	2,4	66,11	3,0	87,5	IE4	87,3	85,8	84,3	87,4	0,652	0,548	0,413	53	62	0,01152	44,0
37	50	250M-6	986	63,62	304,50	4,6	368,30	524,43	1,4	817,68	2,2	94,6	IE4	95,1	94,7	93,3	94,5	0,916	0,900	0,846	65	75	1,06640	420,0
75	100	315S-6	990	132,10	901,10	6,7	724,50	1461,70	2,0	1534,80	2,1	95,4	IE4	94,0	92,6	94,6	95,4	0,860	0,843	0,805	66	82	4,18775	855,0
90	125	315MA-6	990	161,9	1090,70	6,7	869,20	1754,10	2,0	1841,80	2,1	95,6	IE4	94,2	92,8	94,9	95,6	0,840	0,823	0,787	65	82	6,04670	920,0
110	150	315LA-6	990	195,10	1314,60	6,7	1062,20	2143,90	2,0	2251,10	2,1	95,8	IE4	94,4	93,0	95,1	95,8	0,850	0,833	0,796	60	82	6,59450	1111,0
132	180	315LB-6	985	230,9	1554,00	6,7	1281,00	2572,00	2,0	2701,00	2,1	96,0	IE4	94,6	93,2	95,4	96,0	0,860	0,843	0,805	68	82	7,40520	1254,0
160	220	355MA-6	990	276,1	1858,40	6,7	1544,80	3118,40	2,0	3274,30	2,1	96,2	IE4	94,8	93,3	95,6	96,2	0,870	0,853	0,815	68	84	11,49500	1705,0
200	270	355MB-6	980	344,7	2318,00	6,7	1950,50	3897,00	2,0	4092,00	2,1	96,3	IE4	94,9	93,4	95,8	96,3	0,870	0,853	0,815	63	84	12,58400	1760,0
250	335	355L-6	970	429,9	2897,00	6,7	2463,10	4872,00	2,0	5116,00	2,1	96,5	IE4	95,1	93,6	95,8	96,3	0,870	0,853	0,815	70	85	15,00400	1870,0
315	423	400L-6	990	548,99	3568,44	6,5	3038,64	6077,27	2,0	6685,00	2,2	96,3	IE4	96,4	95,4	95,8	96,3	0,860	0,730	0,605	70	98	16,80000	3045,0
355	483	400LA-6	990	618,70	4021,58	6,5	3424,49	6848,99	2,0	7533,89	2,2	96,3	IE4	96,4	95,4	95,8	96,3	0,860	0,730	0,605	70	98	19,45000	3150,0
400	544	400LB-6	990	697,13	4531,35	6,5	3858,59	7717,17	2,0	8488,89	2,2	96,3	IE4	96,4	95,4	95,8	96,3	0,860	0,730	0,605	70	98	21,88000	3270,0
450	620	400LC-6	990	784,27	5097,77	6,5	4340,91	8681,82	2,0	9550,00	2,2	96,3	IE4	96,4	95,4	95,8	96,3	0,860	0,730	0,605	70	102	22,56000	3430,0
500	675	400LD-6	990	871,41	5664,19	6,5	4823,23	9646,46	2,0	10611,11	2,2	96,3	IE4	96,4	95,4	95,8	96,3	0,860	0,730	0,605	70	102	23,79000	3620,0
0,75	1	100LA-8	713	2,15	8,73	4,1	10,05	21,87	2,2	27,50	2,7	79,7	IE4	78,9	73,8	75,0	78,4	0,633	0,542	0,419	34	57	0,01362	19,3
37	50	280S-8	740	71,01	309,30	4,3	489,80	758,66	1,5	995,56	0,4	93,3	IE4	93,8	93,0	90,3	93,1	0,826	0,785	0,689	67	76	8,78078	500,0
90	125	315LA-8	742	169,30	683,30	4,1	1175,90	1398,64	1,2	2219,05	2,0	94,7	IE4	95,3	94,9	93,4	94,4	0,819	0,794	0,725	67	82	25,15510	1055,0



Any 2D or 3D PDF datasheet, or 3D CAD model, with or without gearboxes, VFDs, and special executions, can be downloaded by <https://www.motive.it/en/configuratore.php>



NOTE: motors can be improved in any moment. The data in www.motive.it can be more updated. Each data is even more detailed and proven by the type test reports loaded in <https://www.motive.it/en/rapporti.php>. Also the IE4 motors list is being increased constantly.

COMPONENTS LIST

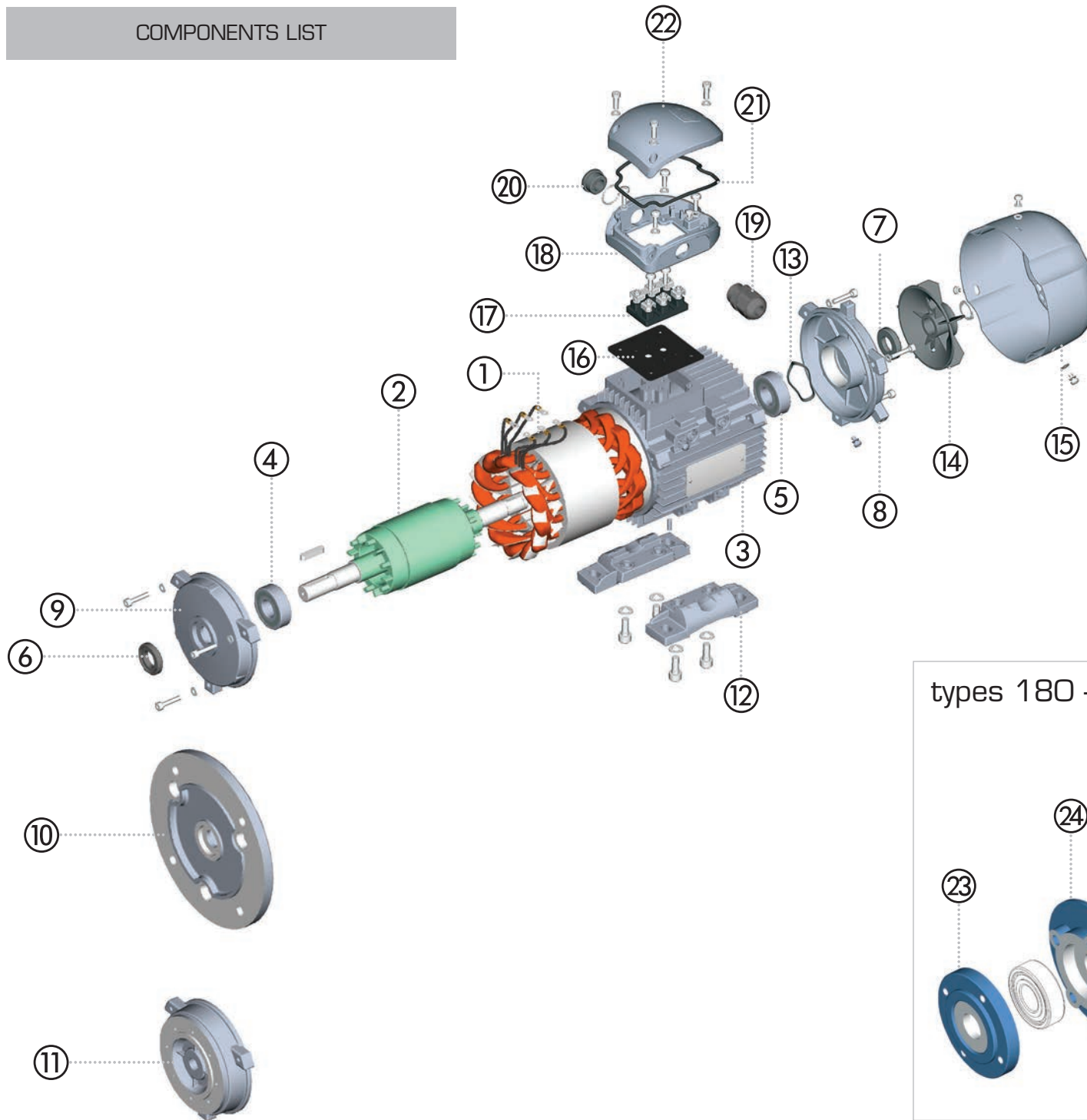

N°	CODE
1	3PNSTA
2	3PNROT
3	3PNFRA
4	3PNFBE
5	3PNBBE
6	3PNFOS
7	3PNBOS
8	3PNBSH
9	3PNBO3
10	3PNBO5
11	3PNB14
12	3PNFEE
13	3PNWAV

N°	CODE
14	3PNFAN
15	3PNFCV
16	3PNUCB
17	3PNTER
18	3PNBCB
19	3PNCMP
20	3PNCAP
21	3PNSCB
22	3PNCCB
23	3PNFOB
24	3PNFIB
25	3PNBIB
26	3PNBOB

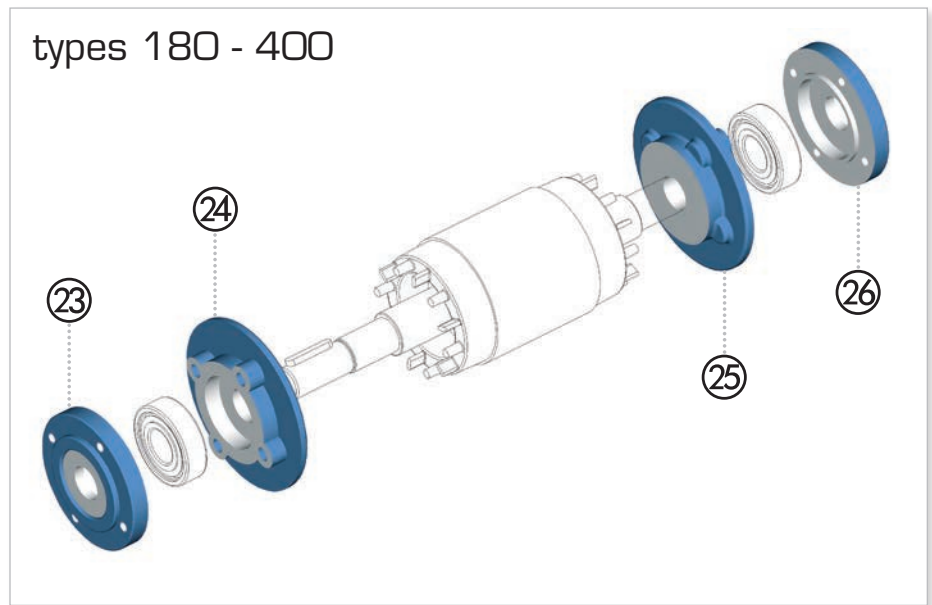

RUBBER SEAL RINGS AND BEARINGS

FRAME SIZE	POLES NUMBER	RUBBER SEAL RING		BEARINGS	
		⑥	⑦	④	⑤
56	2 - 8	12x24x7	12x24x7	6201 ZZ-C3	6201 ZZ-C3
63	2 - 8	12x24x7	12x24x7	6201 ZZ-C3	6201 ZZ-C3
71	2 - 8	15x30x7	15x26x7	6202 ZZ-C3	6202 ZZ-C3
80	2 - 8	20x35x7	20x35x7	6204 ZZ-C3	6204 ZZ-C3
90	2 - 8	25x40x7	25x40x7	6205 ZZ-C3	6205 ZZ-C3
100	2 - 8	30x47x7	30x47x7	6206 ZZ-C3	6206 ZZ-C3
112	2 - 8	30x47x7	30x47x7	6206 ZZ-C3	6206 ZZ-C3
132	2 - 8	40x62x8	40x62x8	6208 ZZ-C3	6208 ZZ-C3
160	2 - 8	45x62x8	45x62x8	6309 ZZ-C3	6309 ZZ-C3
180	2 - 8	55x72x8	55x72x8	6311 ZZ-C3	6311 ZZ-C3
200	2 - 8	60x80x8	60x80x8	6312 ZZ-C3	6312 ZZ-C3
225	2 - 8	65x80x10	65x80x10	6313 ZZ-C3	6313 ZZ-C3
250	2 - 8	70x90x10	70x90x10	6314 ZZ-C3	6314 ZZ-C3
280	2	70x90x10	70x90x10	6314 ZZ-C3	6314 ZZ-C3
280	4 - 8	85x100x12	85x100x12	6317 ZZ-C3	6317 ZZ-C3
315	2	85x110x12	85x110x12	6317-C3	6317-C3
315	4 - 8	95x120x12	95x120x12	NU 319-C3	6319-C3
355	2	95x120x12	95x120x12	6319-C3	6319-C3
355	4 - 8	110x130x12	110x130x12	NU 322-C3	6322-C3
400	4 - 8	130x160x12	130x160x12	NU 326-C3	6326-C3

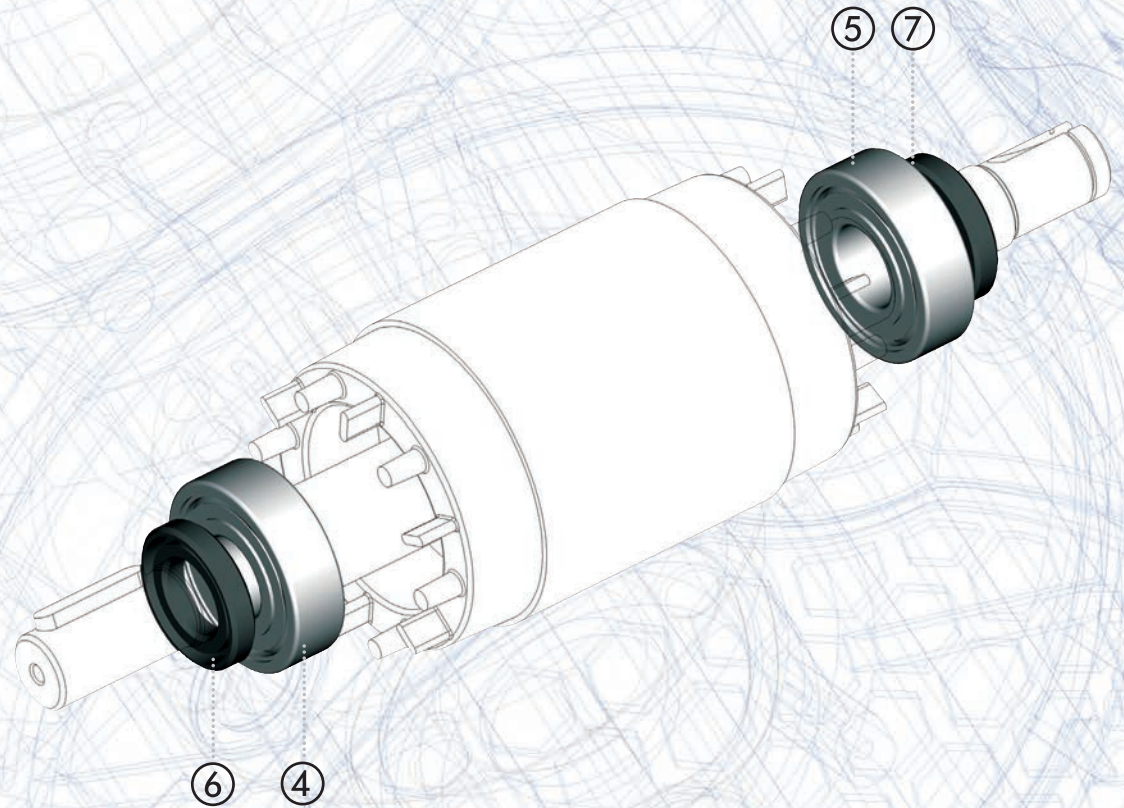

"bearing lubrication devices" are an optional.

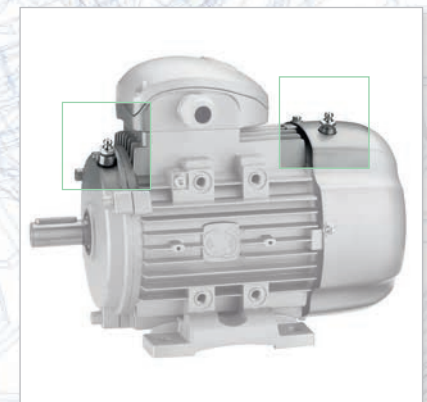

TERMS OF SALE AND GUARANTEE

ARTICLE 1 GARANTEE

1.1. Barring written agreements, entered into between the parties hereto each time, Motive hereby guarantees compliance of products supplied and compliance with specific agreements. The guarantee for defects shall be restricted to product defects following design, materials or manufacturing defects leading back to Motive.

The Guarantee shall not include:

- * faults or damages ensuing from transport., faults or damages ensuing from installation defects; incompetent use of the product, or any other unsuitable use.
- * tampering or damages ensuing from use by non - authorised staff and/or use of non - original parts and/or spare parts;
- * Defects and/or damages ensuing from chemical agents and/or atmospheric phenomena (e.g. burnt out material, etc.); routine maintenance and required action or checks;
- * Products lacking a plate or having a tampered plate.

1.2. Returns to credit or replace will be accepted only in exceptional cases; However returns of goods already used to credit or replace won't be accepted in any case. The guarantee shall be effective for all Motive products, with a term of validity of 12 months, starting from the date of shipment. The guarantee shall be subject to specific written request for Motive to take action, according to statements, as described at the paragraphs hereinbelow. By virtue of aforesaid approval, and as regards the claim, Motive shall be bound, at its discretion, and within a reasonable time-limit, to alternatively take the following action:

- a) To supply the Buyer with products of the same type and quality as those having proven defective and not complying with agreements, free ex-works; in aforesaid case, Motive shall have the right to request, at the Buyer's charge, early return of defective goods, which shall become Motive's property;
- b) To repair, at its charge, the defective product or to modify the product which does not comply with agreements, by performing aforesaid action at its facilities; in aforesaid cases, all costs regarding product transport shall be sustained by the Buyer.
- c) To send spare parts free of charge: all costs regarding product transport shall be sustained by the Buyer.

1.3 The guarantee herein shall assimilate and replace legal guarantees for defects and discrepancies, and shall exclude any other eventual Motive liability, however caused by supplied products; in particular, the Buyer shall have no right to submit any further claims. Motive shall not be liable for the enforcement of any further claims, as of the date the guarantee's term of validity expires.

ARTICLE 2 CLAIMS

2.1. Without prejudice to the application of provisions in Law, dated June 21, 1971, and as per Article 1: Claims, regarding quantity, weight, gross weight and colour, or claims regarding faults and defects in quality or compliance, and which the Buyer may discover on goods delivery, shall be submitted by a max. 7 days of aforesaid discovery, under penalty of nullity.

ARTICLE 3 DELIVERY

3.1. Any liability for damages ensuing from total or partial delayed or failed delivery, shall be excluded.

3.2. Unless differently communicated by written to the Client, the transport terms have to be intended ex-works

ARTICLE 4 PAYMENT

4.1. Any delayed or irregular payments shall entitle Motive to cancel ongoing agreements, including agreements which do not regard the payments at issue, as well as entitling Motive to claim damages, if any. Motive shall, however, have the right, as of the payment's due date and without placing in arrears, to claim interest for arrears, to the extent of the discount rate in force in Italy, increased by 5 points. Motive shall also have the right to withhold material under repair for replacement. In the case of failed payment, Motive shall have the right to cancel all guarantees on materials, as regards the insolvent Client.

4.2. The Buyer shall be bound to complete payment, including cases whereby claims or disputes are underway.



**DOWNLOAD
THE TECHNICAL
MANUAL FROM
WWW.MOTIVE.IT**

ALL DATA HAVE BEEN WRITTEN AND CHECKED WITH THE GREATEST CARE. WE DO NOT TAKE ANY RESPONSIBILITY FOR POSSIBLE ERRORS OR OMISSIONS. MOTIVE CAN CHANGE THE CHARACTERISTICS OF THE SOLD ITEMS ON HIS FIRM OPINION AND IN EVERY MOMENT.



You can download each motor or gearbox final test report from <https://report.motivesrl.it/> starting from its serial number

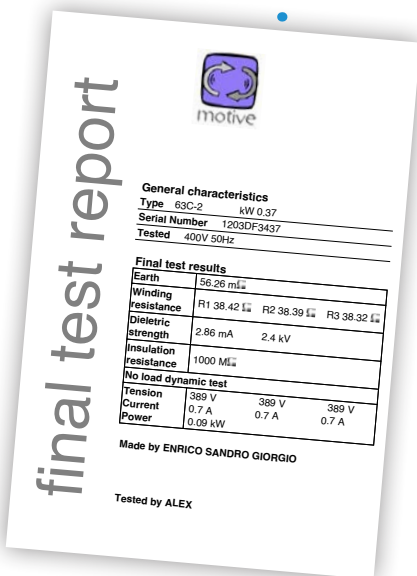

final test report



General characteristics

Type 63C-2 kW 0.37

Serial Number 1203DF3437

Tested 400V 50Hz

Final test results

Earth 56.26 mΩ

Winding Resistance R1 38.42 Ω R2 38.39 Ω R3 38.32 Ω

Dielectric strength 2.86 mA 2.4 kV

Insulation resistance 1000 MΩ

No load dynamic test

Tension 389 V 389 V 389 V

Current 0.7 A 0.7 A 0.7 A

Power 0.09 kW 0.7 A 0.7 A

Made by ENRICO SANDRO GIORGIO

Tested by ALEX

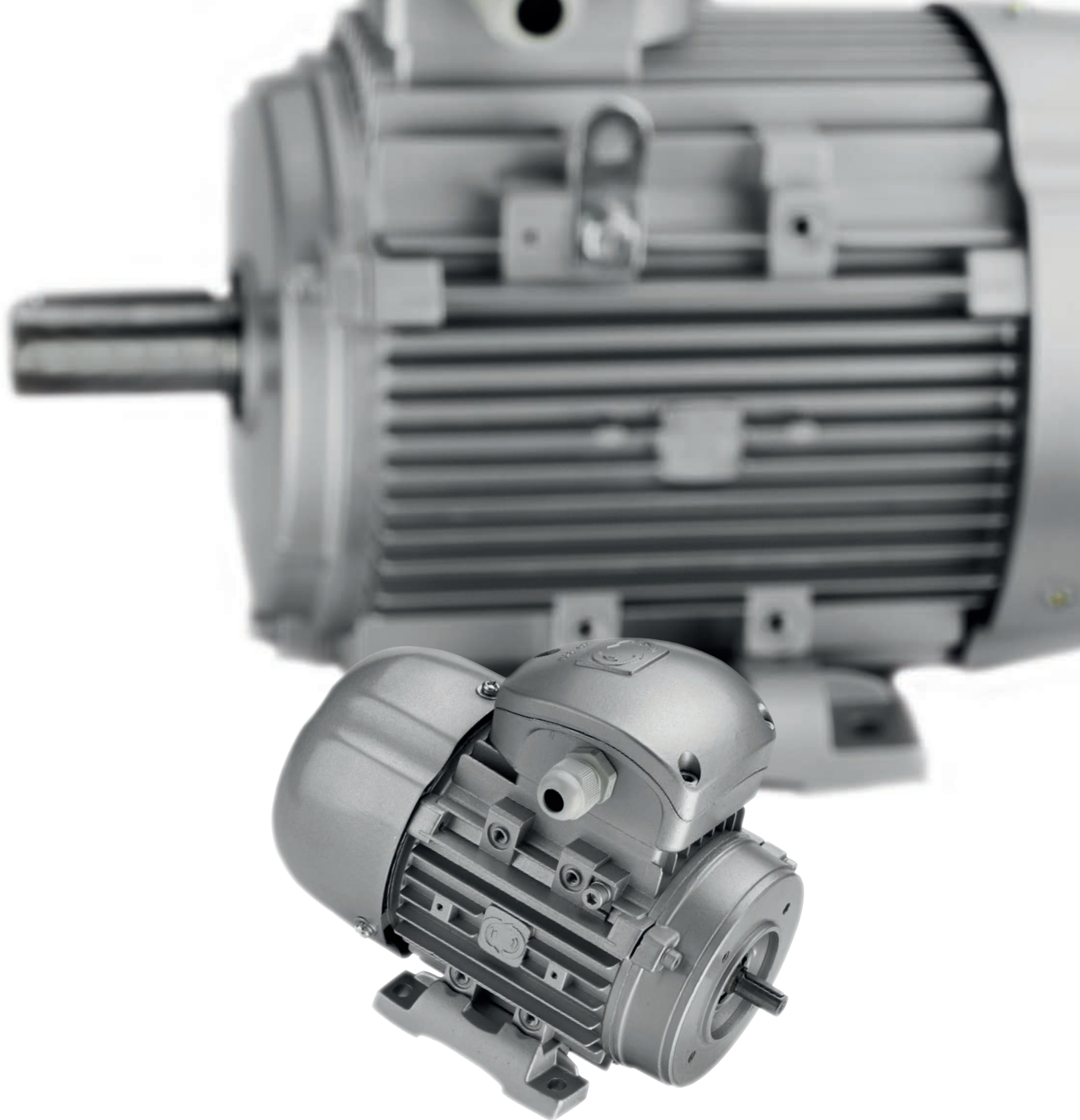

ASK OUR FURTHER CATALOGUES:



Motive s.r.l.

Via Le Ghiselle, 20

25014 Castenedolo (BS) - Italy

Tel.: +39.030.2677087 - Fax: +39.030.2677125

web site: www.motive.it

e-mail: motive@motive.it



AREA DISTRIBUTOR