



FPA

PRESSURE FILTERS

DESCRIPTION

Medium pressure inline filter

MATERIALS

Housing: Anodized aluminum alloy
Bypass valve: Brass
Seals: NBR Nitrile (FKM Fluoroelastomer on request)
Indicator housing: Brass

PRESSURE

Max working: 11 MPa (110 bar)
Collapse, differential for the filter element:
8 MPa (80 bar)

BYPASS VALVE

Setting: 600 kPa (6 bar) \pm 10%

FLOW RATE

Qmax 60 l/min

WORKING TEMPERATURE

From -25° to +110° C

COMPATIBILITY (ISO 2943)

Full with fluids: HH-HL-HM-HV-HTG
(according to ISO 6743/4)
For fluids different than the above mentioned,
please contact our Customer Service

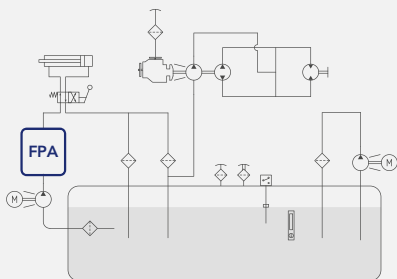

Is this datasheet the latest release? Please check on our website

FPA

PRESSURE FILTERS

ORDERING AND OPTION CHART

F	P	A	COMPLETE FILTER FAMILY			FILTER ELEMENT FAMILY	E	P	A
			SIZE & LENGTH	11	12	SIZE & LENGTH			
			PORT TYPE						
			B = BSP thread	B	B				
			N = NPT thread *	N	N				
			S = SAE thread *	S	S				
			PORT SIZE						
			04 = 1/2" (N04 not available)	04	04				
			BYPASS VALVE						
			W = without	W	W				
			C = 600 kPa (6 bar)	C	C				
			SEALS			SEALS			
			N = NBR Nitrile	N	N				
			F = FKM Fluoroelastomer	F	F				
			G = Treatment for water-glycol	G	G				
			FormulaUFI MEDIA			FormulaUFI MEDIA			
			FA = FormulaUFI.MICRON 5 $\mu\text{m}_{(c)}$ $\beta > 1.000$	FA	FA				
			FB = FormulaUFI.MICRON 7 $\mu\text{m}_{(c)}$ $\beta > 1.000$	FB	FB				
			FC = FormulaUFI.MICRON 12 $\mu\text{m}_{(c)}$ $\beta > 1.000$	FC	FC				
			FS = FormulaUFI.MICRON 16 $\mu\text{m}_{(c)}$ $\beta > 1.000$	FS	FS				
			FD = FormulaUFI.MICRON 21 $\mu\text{m}_{(c)}$ $\beta > 1.000$	FD	FD				
			FE = FormulaUFI.MICRON 30 $\mu\text{m}_{(c)}$ $\beta > 1.000$	FE	FE				
			CLOGGING INDICATOR **						
			03 = port, plugged	03	03				
			5E = visual differential 500 kPa (5 bar)	5E	5E				
			6E = electrical differential 500 kPa (5 bar)	6E	6E				
			7E = indicator 6E with LED	7E	7E				
			T2 = elect. diff. 500 kPa (5 bar) with thermostat 30°C	T2	T2				
X	X		ACCESSORI / ACCESSORIES						
			XX = no accessories available	XX	XX				

* Not standard version, please check availability with our Customer Service

**When the filter is ordered with FKM seals, the first digit of the indicator code is a letter (please see Clogging Indicator Chapter for further details)

SPARE PARTS

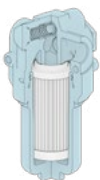
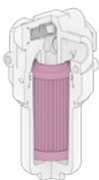
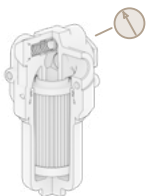
FILTER HOUSING										FILTER ELEMENT					CLOGGING INDICATOR				
																			
B	P	A				0	4												



SPARE SEAL KIT

	NBR	FKM
FPA11 - 12	521.0001.2	521.0062.2

INSTALLATION DRAWING

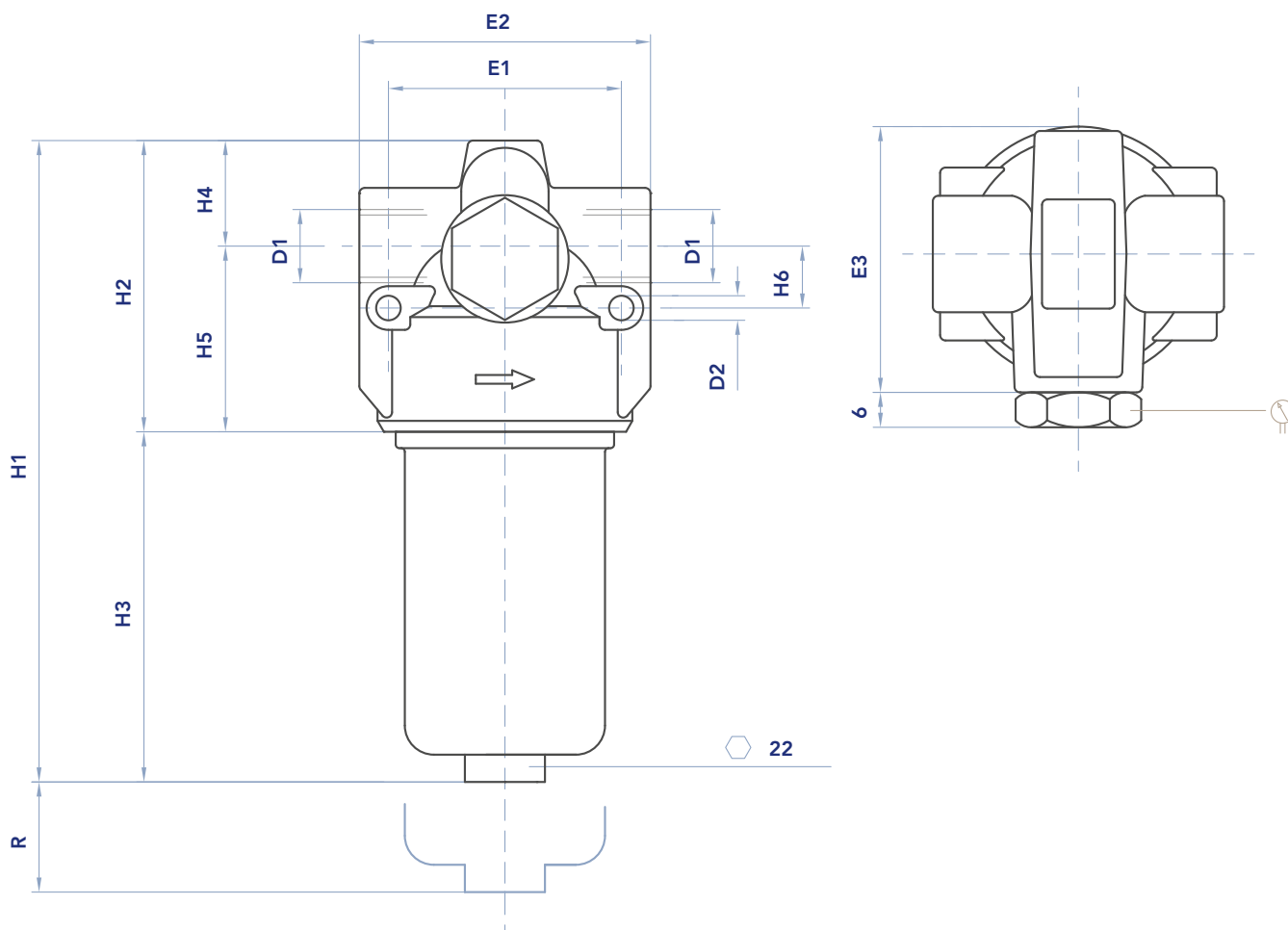

FILTER HOUSING

	D1	D2	H1	H2	H3	H4	H5	H6	E1	E2	E3	R	Kg
FPA11	1/2"	6,5	157	78	79	28	50	17	64	76	75	60	0,65
FPA12	1/2"	6,5	244	78	166	28	50	17	64	76	75	60	0,85

FPA

PRESSURE FILTERS

FILTER ELEMENT

	A	B	C	AREA (cm ²)	
				Kg	Media F+
EPA11	22	42	91	0,15	295
EPA12	22	42	179	0,25	600

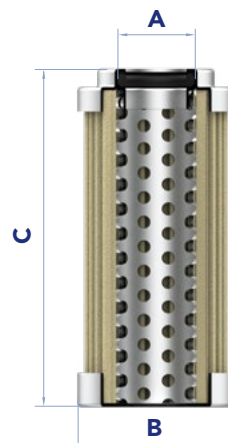

MAINTENANCE

- 1) Stop the system and verify there is no pressure in the filter.
- 2) Collect the oil inside the filter with a suitable container.
- 3) Unscrew the bowl (1) and clean it.
N.B. Never unscrew the by-pass valve (7).
- 4) Remove the dirty filter element (2).
N.B. The exhausted filter elements and the oil dirty filter parts are classified "Dangerous waste material" and must be disposed of according to the local laws, by authorized Companies.
- 5) Check the filter element part number on the filter label or in the ordering and option chart.
Use only original spare parts.
- 6) Lubricate the element o-ring gasket (3) with oil.
- 7) Insert the clean element into its seat with care.
- 8) Check the housing o-ring condition (4) and lubricate with oil.
If damaged, check the seal kit part number in the spare seal kit table.
N.B. The anti-extrusion o-ring (5) must be positioned downwards (under the gasket).
- 9) Screw the bowl (1) until it stops, with a tightening torque of 50 Nm +5/0.

Accessories:

Clogging indicator (6).

If damaged, unscrew and replace (check the part number in the ordering and option chart).

Lubricate the o-ring gasket with oil and tighten until it stops, with a tightening torque of 40 Nm +5/0.

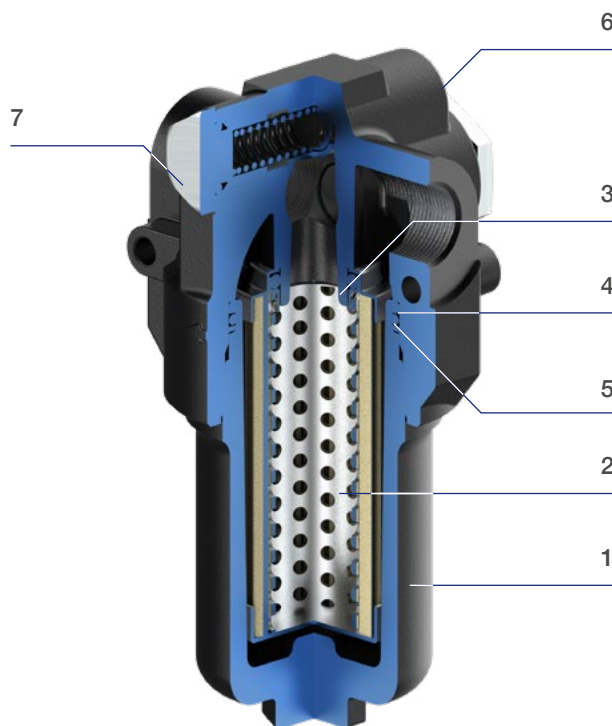



PRESSURE DROP CURVES (Δp)

The “Assembly Pressure Drop (Δp)” is obtained by adding the pressure drop values of the Filter Housing and of the Clean Filter Element corresponding to the considered Flow Rate and it must

be lower than 100 kPa (1 bar). In any case this value should never exceed 1/3 of the bypass valve setting.

BYPASS VALVE PRESSURE DROP

When selecting the filter size, these curves must be taken into account if it is foreseen that any flow peak is to be absorbed by the bypass valve, it also must be of proper configuration to avoid pressure peaks. The valve pressure drop is directly proportional to fluid specific gravity.

FILTER HOUSING PRESSURE DROP
(mainly depending on the port size)

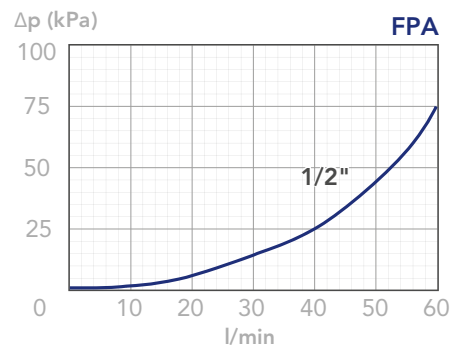
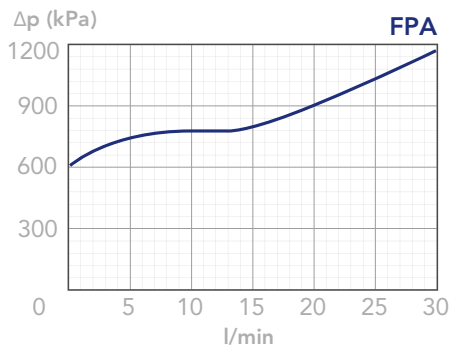

CLEAN FILTER ELEMENT PRESSURE DROP WITH F+ MEDIA
(depending both on the internal diameter of the element and on the filter media)

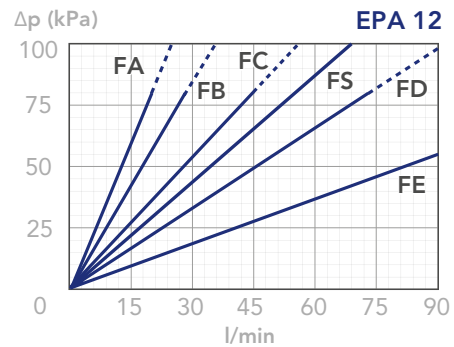
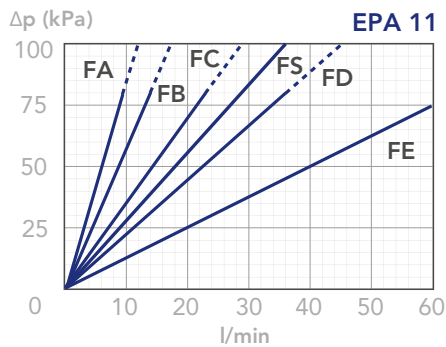

N.B.

All the curves have been obtained with mineral oil having a kinematic viscosity 30 cSt and specific gravity 0,86 kg/dm³; for fluids with different features, please consider the factors described in the first part of this catalogue. All the curves

are obtained from test done at the UFI FILTERS HYDRAULICS Laboratory, according to the specification ISO 3968. In case of discrepancy, please check the contamination level, viscosity and features of the fluid in use.